

User Manual

HDCX-09~95 DC **AC Contactor**

Complied Standard: IEC/EN 60947-4-1

Please carefully read the User Manual before the installation and use of the products, keep it properly as backup.



HDCX-09~95 DC User manual

Safety notification

Please read this manual carefully before installation, operation, maintenance, inspection. Install and use the product accurately according to the contents of the manual.

Danger:

- Do not operate the contactor with water on your hands.
- Do not touch the conductive part while in use.
- During maintenance and care, ensure that the product is electrically neutral.

Attention:

- Installation and maintenance should be operated by professionally qualified personnel.
- Please confirm whether the product operating voltage, rated current, frequency and use category meet the requirements before use.
- Firstly, please connect the control circuit for no-load test, if there is no abnormality, then connect the load.
- Regularly tighten the terminal wiring and remove the deposited dust.
- Do not allow anything else to fall into the product.
- If you need to buy accessories, please choose the matching accessories provided by our company.
- If the product is damaged or has abnormal sound when unpacking, please refuse to use and contact our company.
- Please dispose of end-of-life products in the correct way.
- The main contacts of the contactor are not recommended to be used when the AC load capacity is less than 72VA or the DC load power is less than 72W (e.g., DC control of PLC output), and the HFD6 auxiliary contact set can be used to achieve better results.

Learn about HDCX-09~95 DC products

- Panel introduction

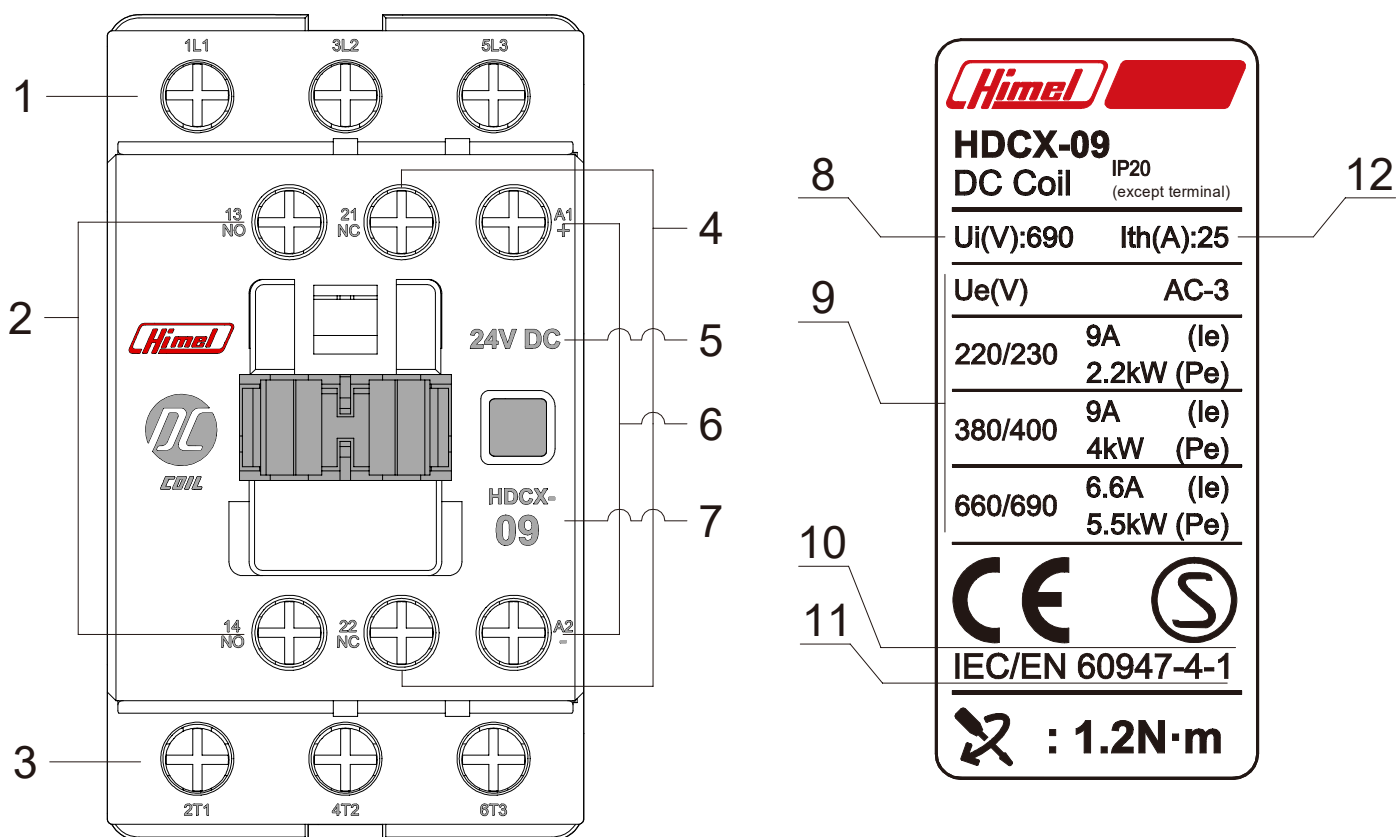

Fig. 1 Product diagram

● Instructions:

- 1--Main circuit inlet terminal 1/L1, 3/L2, 5/L3
 - 2--Normally open auxiliary terminal
 - 3--Main circuit outlet terminal 2/T1, 4/T2, 6/T3
 - 4--Normally close auxiliary terminal
 - 5--Rated control circuit voltage
 - 6--Coil inlet terminal A1, outlet terminal A2
 - 7--Product specification
 - 8--Rated insulation voltage U_i
 - 9--Rated operational current, voltage, power
 - 10--Certification mark
 - 11--Compliant with standard number: IEC/EN 60947-4-1
 - 12-- Conventional free air thermal current
- The specific product parameters are shown in Table 1.

Table. 1

Model			HDCX-09	HDCX-12	HDCX-18	HDCX-25	HDCX-32	HDCX-38	HDCX-40	HDCX-50	HDCX-65	HDCX-80	HDCX-95
Conventional free air thermal current Ith(A)			25		32	40	50		60	80		125	
Rated operational current Ie(A)	AC-3	220V/230V	9	12	18	25	32	38	40	50	65	80	95
		380V/400V	9	12	18	25	32	38	40	50	65	80	95
		660V/690V	6.6	8.9	12	18	22	22	34	39	42	49	49
	AC-4	220V/230V	3.5	5	7.7	8.5	12	14	18.5	24	28	37	44
		380V/400V	3.5	5	7.7	8.5	12	14	18.5	24	28	37	44
		660V/690V	1.5	2	3.8	4.4	7.5	8.9	9	12	14	17.3	21.3
Rated operational power Pe(kW)	AC-3	220V/230V	2.2	3	4	5.5	7.5	9	11	15	19	22	25
		380V/400V	4	5.5	7.5	11	15	18.5	18.5	22	30	37	45
		660V/690V	5.5	7.5	10	15	18.5	18.5	30	33	37	45	45
	AC-4	220V/230V	0.6	1.1	1.5	2.2	3	4	5.5	6	7.5	11	14
		380V/400V	1.5	2.2	3.3	4	5.4	5.5	7.5	11	15	18.5	22
		660V/690V	1.1	1.5	3	3.7	5.5	6	7.5	10	11	15	18.5
Electrical endurance	AC-3	380V/400V	1 million times				0.8 million times				0.65 million times		
Intermittent cycle operation, load factor of 40% rated operational frequency	AC-3	220V/400V	1200 times/h				600 times/h						
		660V/690V	300 times/h										
	AC-4	220V/400V	300 times/h										
		660V/690V	120 times/h										

The permitted utilization categories for contactor main circuit and auxiliary circuit are shown in Table 2.

Table. 2 The permitted utilization categories of contactor main circuit and auxiliary circuit

Circuit categories	Category	Typical applications
Main circuit	AC-1	Non-inductive or slightly inductive loads, resistance furnaces
	AC-2	Slip-ring motors: starting, switching off
	AC-3	Squirrel-cage motors: starting, switching off motors during running
	AC-4	Squirrel-cage motors: starting, plugging, inching
Auxiliary circuit	AC-15	Control AC electromagnet load
	DC-13	Control DC electromagnet load

Conditions of use, installation, and transport

- Conditions of use and installation

- (1) The ambient air temperature ranges between -5°C and $+40^{\circ}\text{C}$ with average value in 24h not exceeding $+35^{\circ}\text{C}$.
- (2) Altitude: $\leq 2000\text{m}$
- (3) The atmosphere relative humidity shall not exceed 50% at the maximum temperature of $+40^{\circ}\text{C}$. Higher relative humidity is possible at lower temperatures, e.g., 90% humidity at 20°C . Protective measures should be taken against occasional condensation due to temperature changes.
- (4) The installation position should be vertical, and the inclination of each direction should not exceed $\pm 22.5^{\circ}$.
- (5) Installed in a place without shock vibration and without rain and snow attack.
- (6) Pollution degree: 3
- (7) Overvoltage category: III
- (8) Rated frequency: 50Hz
- (9) IP degree of protection: IP20 (except terminal)
- (10) Suitable for 8h working system, intermittent cycle working system, uninterrupted working system and short time working system.

- Conditions of storage and transport

- (1) Temperature: $-25^{\circ}\text{C} \sim +55^{\circ}\text{C}$, up to $+70^{\circ}\text{C}$ within a short time (24h).
- (2) Relative humidity: $\leq 95\%$
- (3) The product should be transported gently, without inversion and strong impact.
- (4) The product must not be exposed to rain or snow during transport and storage.

Product installation

- The contactors are available in both screw and DIN rail mounting. HDCX-09~65 can be installed with 35mm DIN rail. HDCX-80~95 can be installed with 35mm DIN rail and 75mm DIN rail. Before installation, check whether the rated voltage and frequency of the coil are consistent with the control power supply. Do not use when the contactor is damaged or not securely assembled. Installation and disassembly methods are shown in Figure 2, Figure 3, Figure 4 and Figure 5.

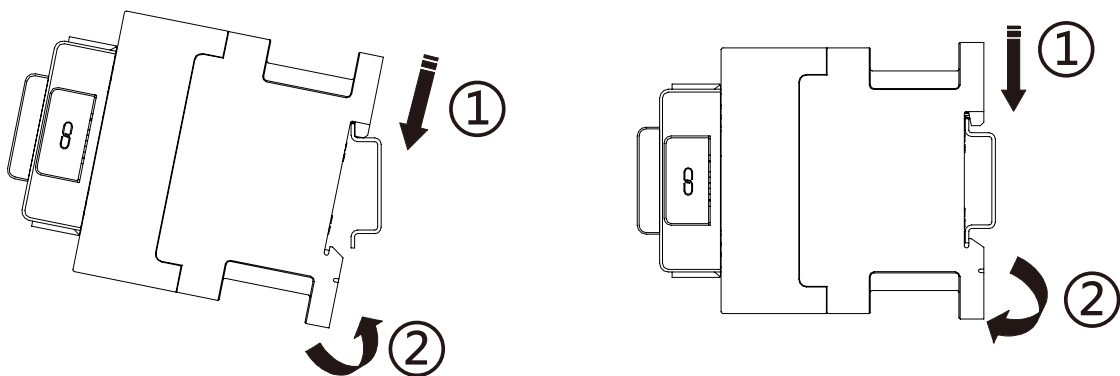
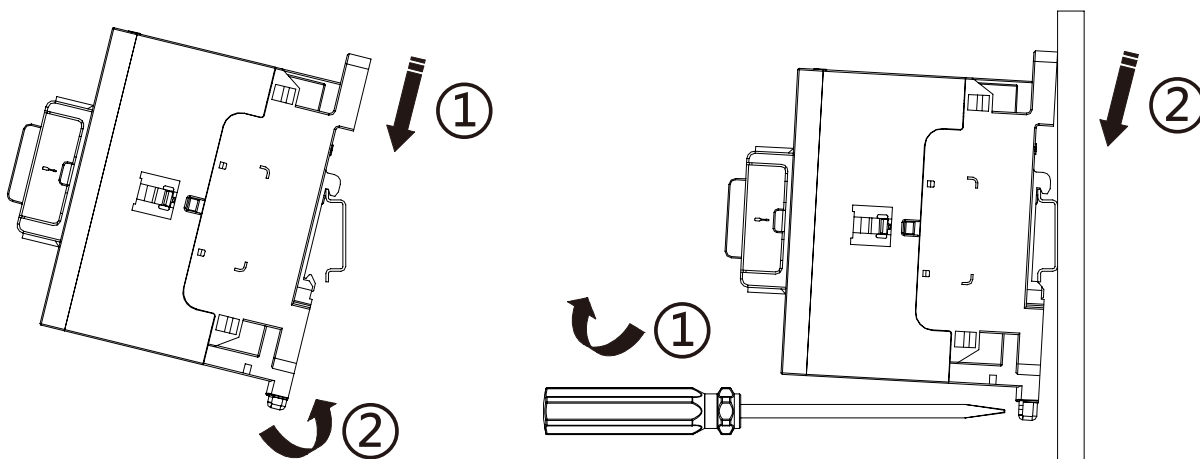

Fig. 2 HDCX-09~38DC Installation and disassembly methods



Installation methods one

Installation methods two

Disassembly method

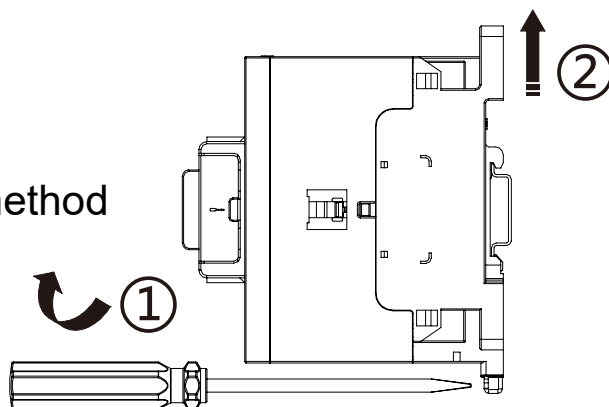
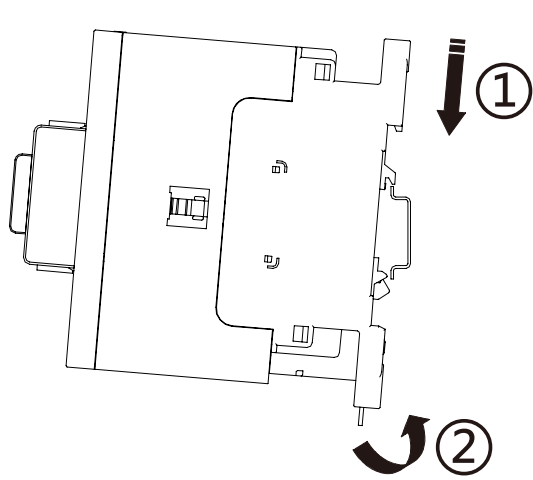
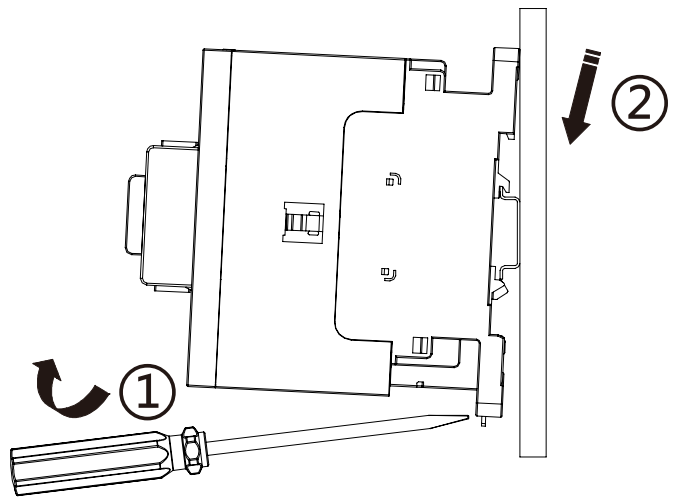

Fig. 3 HDCX-40~65 DC Installation and disassembly methods



Installation methods one



Installation methods two

Disassembly method

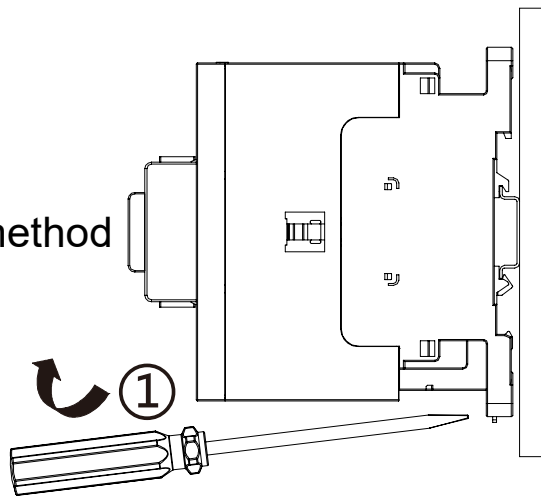

Fig. 4 HDCX-80~95 DC Installation with 35mm DIN railand disassembly methods

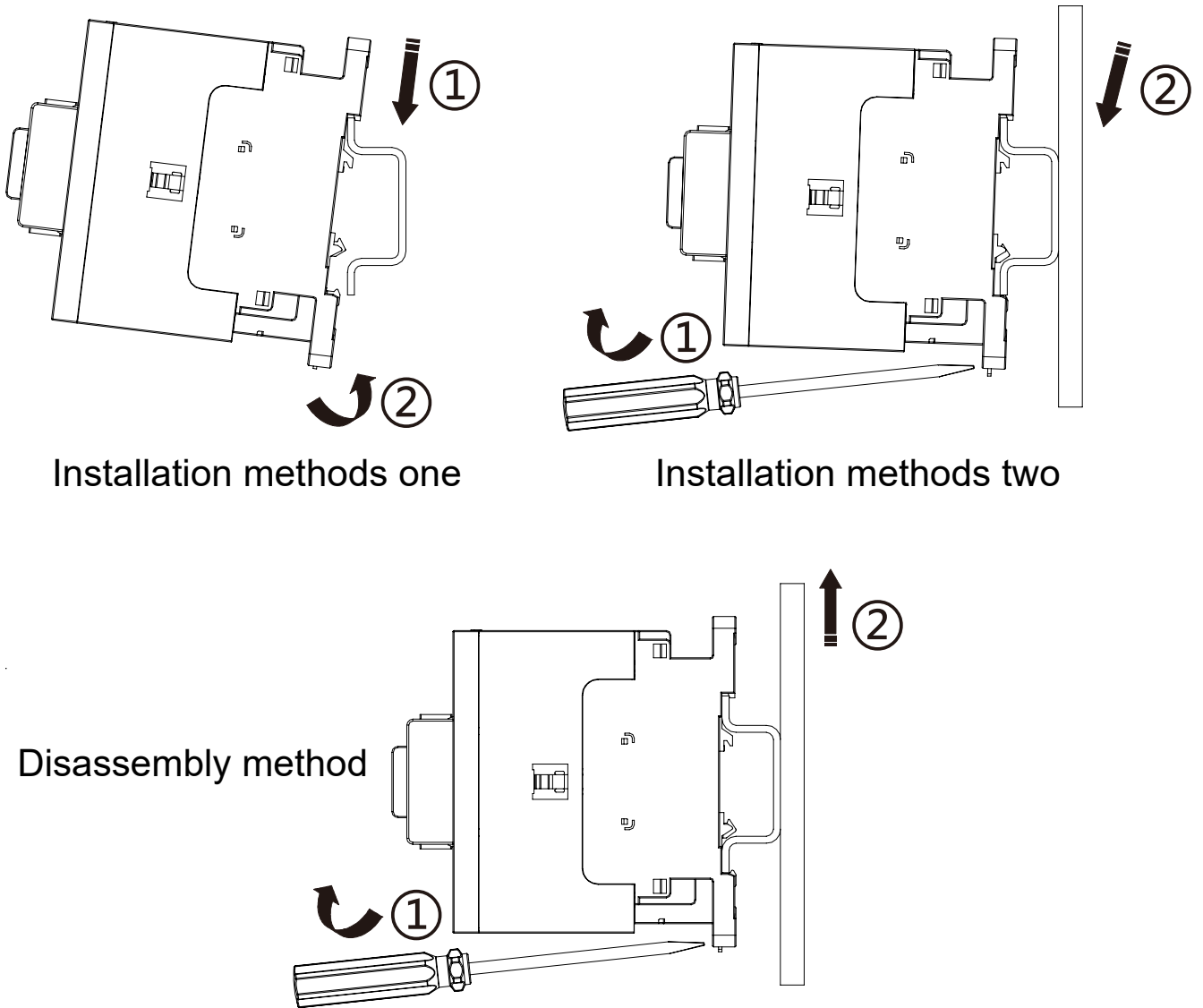

Fig. 5 HDCX-80~95 DC Installation with 75mm DIN railand disassembly methods

- Product installation requirements are shown in Figure 6.

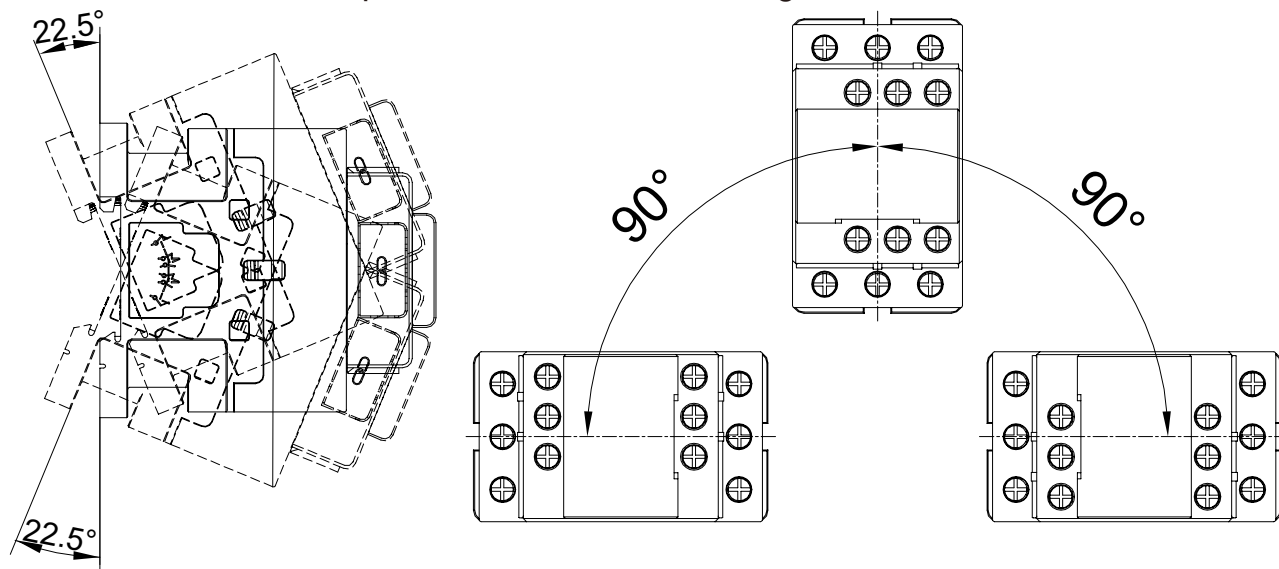

Fig. 6 Installation requirements

- The contactor overall installation dimensions are shown in Figure 7, Figure 8, Figure 9 and Table 3.

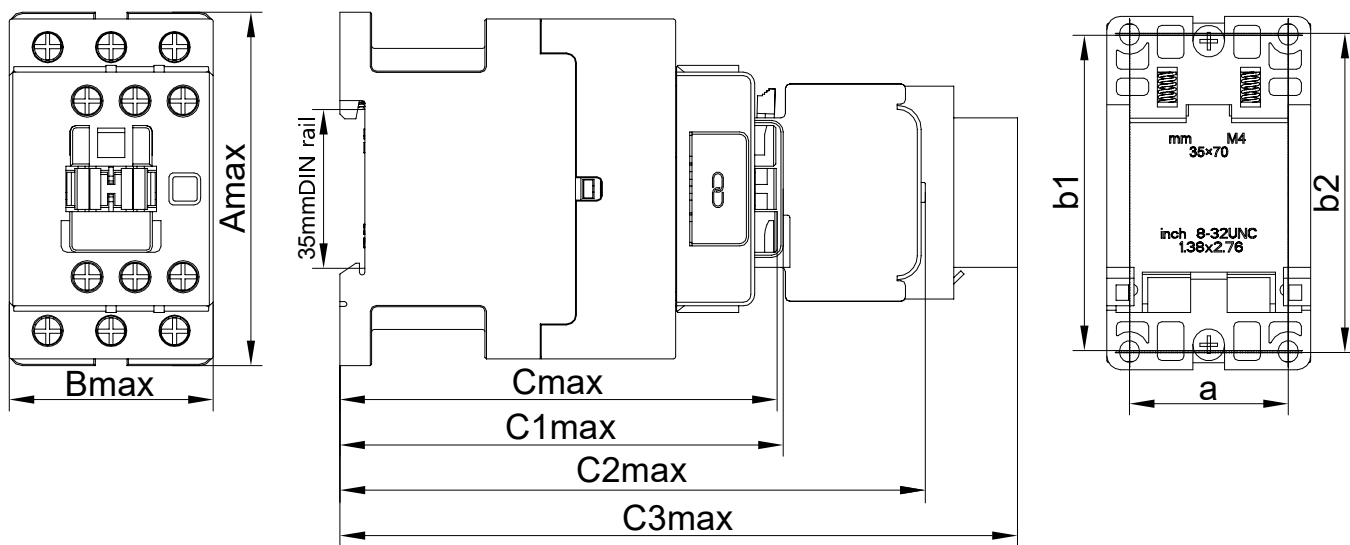

Fig. 7 HDCX-09~38 DC

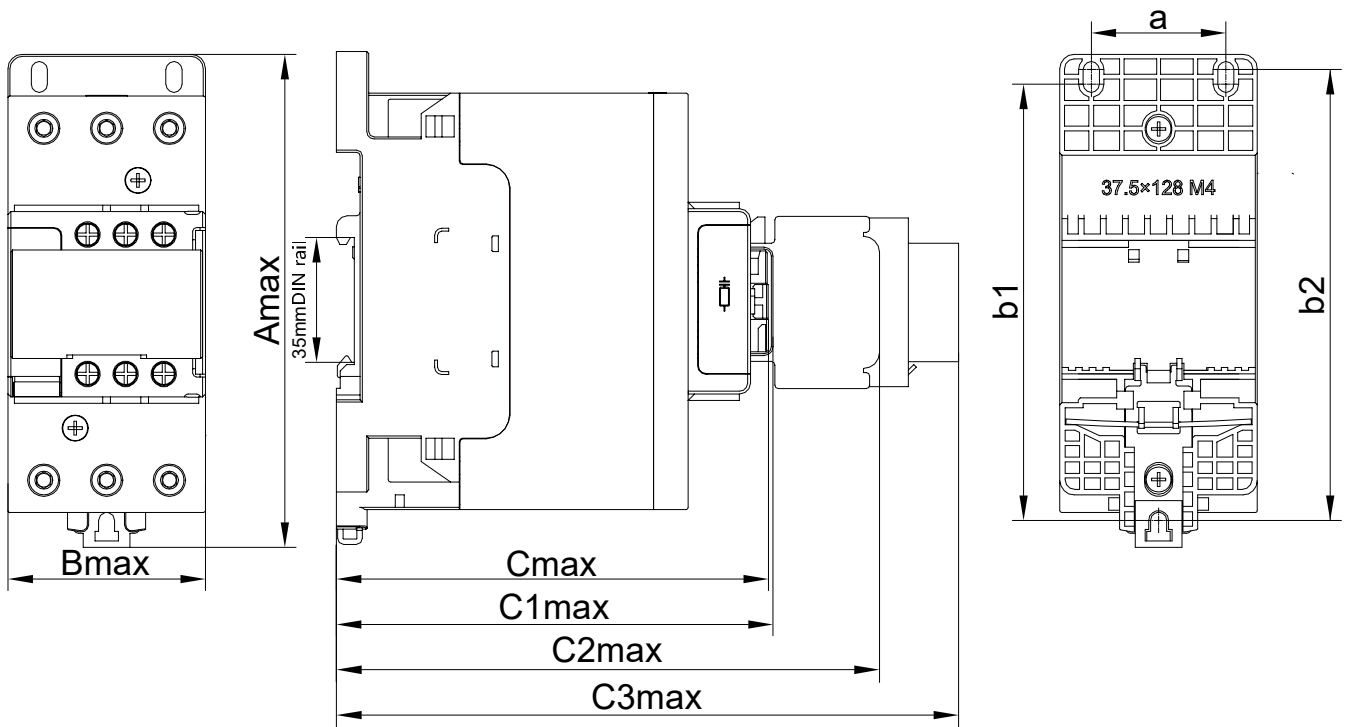

Fig. 8 HDCX-40~65 DC

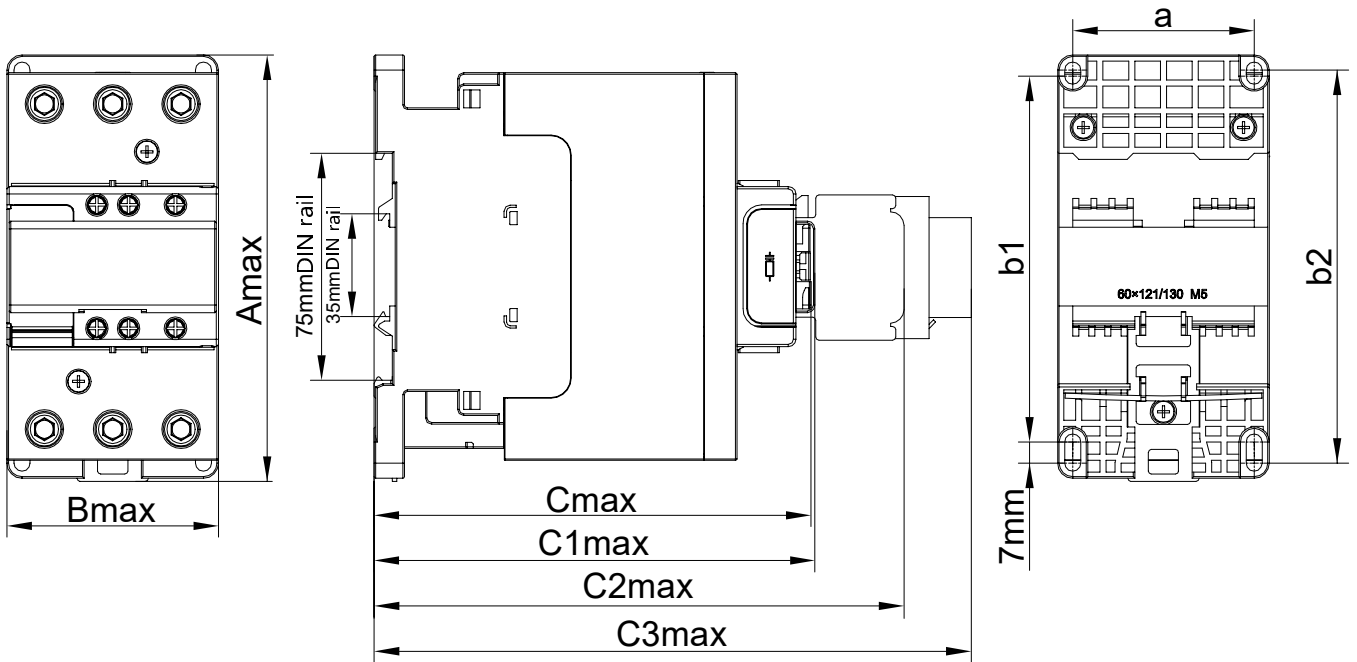

Fig. 9 HDCX-80~95 DC

Table. 3 HDCX-09~95 DC contactor overall installation dimensions

Unit: mm

Model	Amax	Bmax	Cmax	C1max	C2max	C3max
HDCX-09、 12、 18 DC	79	45.5	97	98.5	130	155
HDCX-25、 32、 38 DC	86.5	45.5	103	104.5	136	161
HDCX-40、 50、 65 DC	138.3	55.8	121.3	122.6	157.3	178.3
HDCX-80、 95 DC	142	71	145.9	147.2	179	199
Note: C1max—Contactor+Dust Cap C2max—Contactor+HFD6 C3max—Contactor+HFT6						
Model	a	b1	b2	-	-	-
HDCX-09、 12、 18 DC	35±0.2	69.6±0.2	70.4±0.5	-	-	-
HDCX-25、 32、 38 DC	35±0.2	69.6±0.2	70.4±0.5	-	-	-
HDCX-40、 50、 65 DC	37.5±0.5	121±0.5	129±0.5	-	-	-
HDCX-80、 95 DC	60±1	121±1	130±1	-	-	-

- The reversible contactor overall installation dimensions are shown in Figure 10, Figure 11, Figure 12 and Table 4.

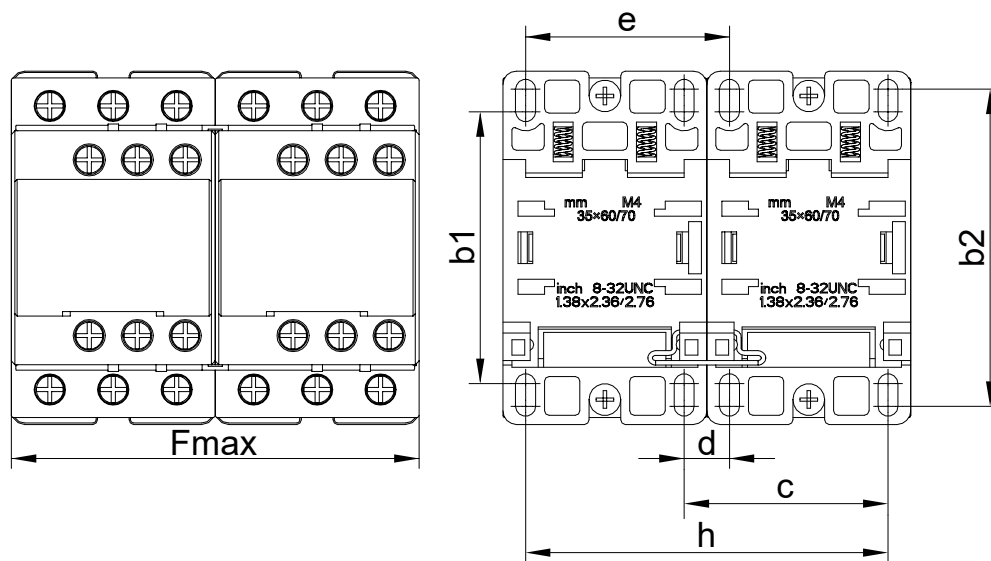

Fig. 10 HDCX-09~38 DC reversible contactor overall installation dimension

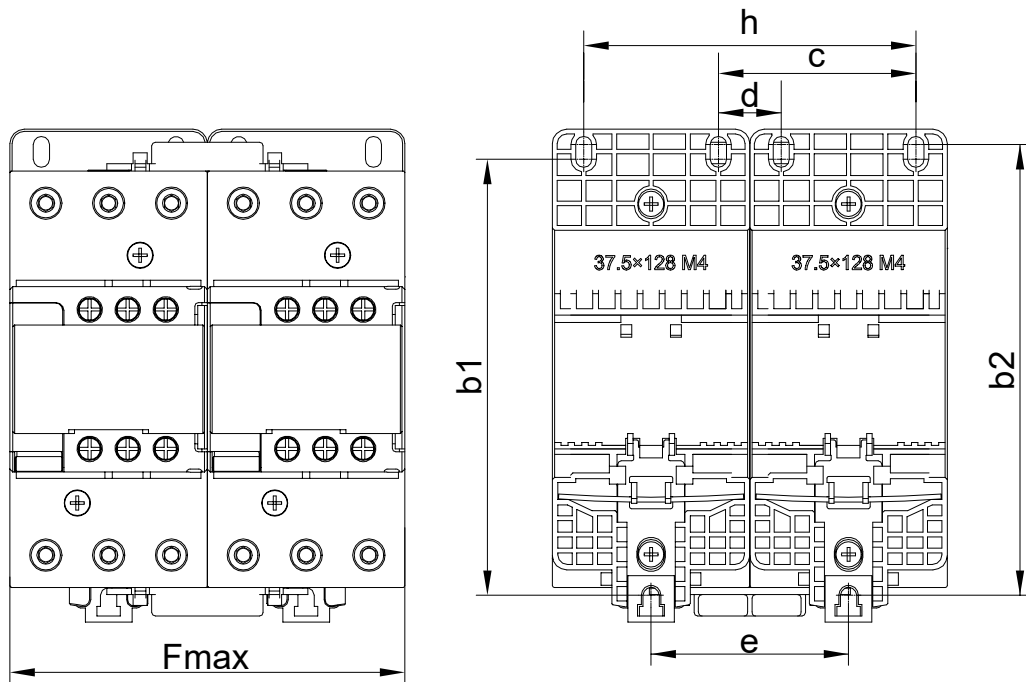

Fig. 11 HDCX-40~65 DC reversible contactor overall installation dimension

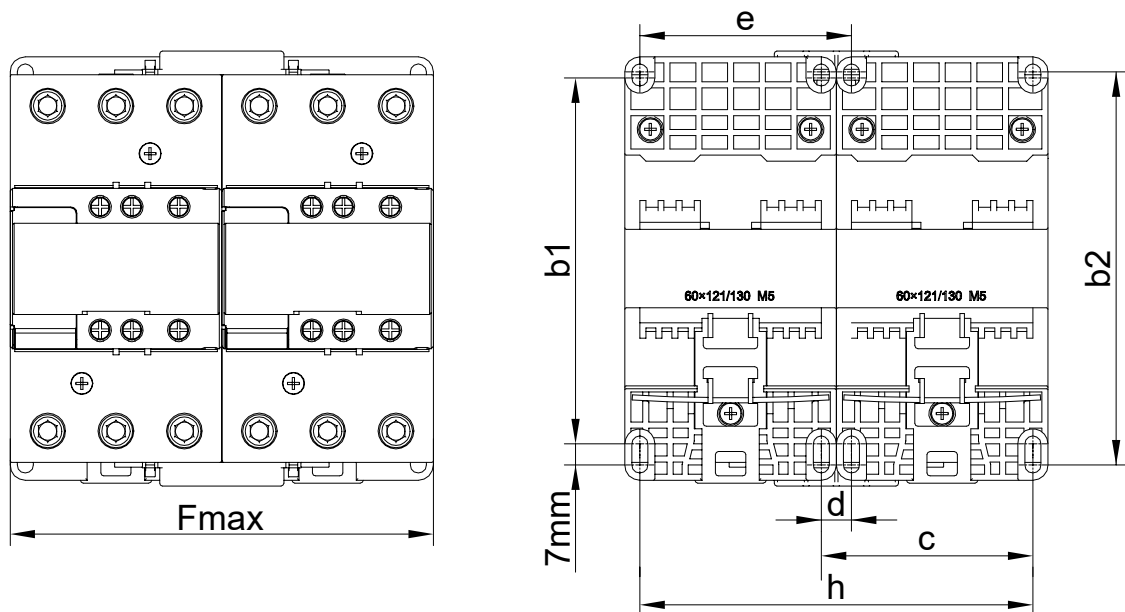

Fig. 12 HDCX-80~95 DC reversible contactor overall installation dimension

Table. 4 HDCX-09~95 DC reversible contactor overall installation dimensions

Model	Fmax	b1	b2	Unit: mm			
				c	d	e	h
HDCX-09、12、18 DC	90	69.6±0.2	70.4±0.5	45±0.5	10±0.5	45±0.5	80±0.8
HDCX-25、32、38 DC	90	69.6±0.2	70.4±0.5	45±0.5	10±0.5	45±0.5	80±0.8
HDCX-40、50、65 DC	111	121±0.5	129.5±0.5	55±0.8	17.5±0.5	55±0.8	92.5±0.8
HDCX-80、95 DC	141	121±1	130±1	70±1	10±1	70±1	130±1

- Accessory installation

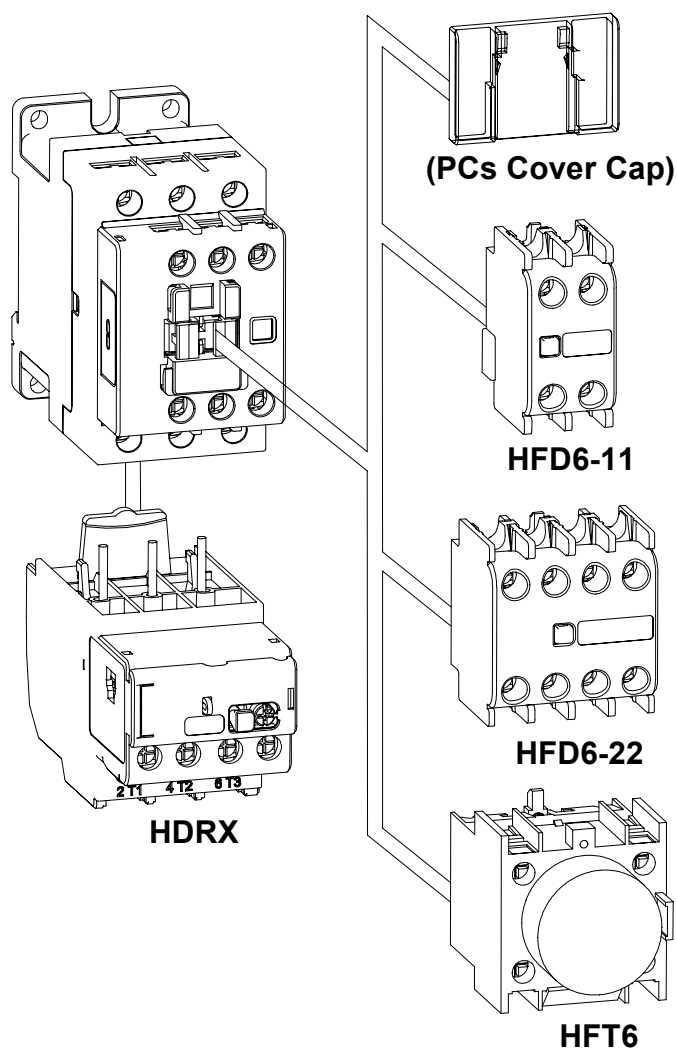

Fig. 13 Accessories installation diagram

(1) Auxiliary contact

HDCX-09~95 DC contactor has a pair of normally open and a pair of normally close auxiliary contact group, the main parameters are shown in Table 5.

Table. 5 Auxiliary contacts main parameters

Category	Rated insulation voltage U_i	Conventional free air thermal current I_{th}	Rated making-breaking capacity		Rated operational current I_e	
			making	breaking	220V	380V
AC-15	690V	10A	3600VA	360VA	1.6A	0.95A
DC-13			33W		0.15A	-

Also the contactor can be equipped with independent auxiliary contact modules, and their models, specifications, and normally open and normally closed combinations are listed in Table 6. Their references of the normal open and close combination are also shown in Table 5. The installation and disassembly method of HFT6 is illustrated in Figure 14, Figure 15. The HFD6 installation method consist with the HFT6 air delayed head.

Table. 6 Auxiliary contact group

Model	HFD6-20	HFD6-11	HFD6-02	HFD6-40	HFD6-31	HFD6-22	HFD6-13	HFD6-04
Number of NO	2	1	0	4	3	2	1	0
Number of NC	0	1	2	0	1	2	3	4

(2) Air delayed head

The contactor can be equipped with HFT6 air delayed head to combine into a delay contactor, and its delay range is shown in Table 7.

Table. 7 Air delayed head

Model	Delay range	Number of delay contacts	Delay category
HFT6-20	0.1 ~ 3s	1NO+1NC	Power-on delay
HFT6-22	0.1 ~ 30 s		
HFT6-24	10 ~ 180s		
HFT6-30	0.1 ~ 3s		Power-off delay
HFT6-32	0.1 ~ 30 s		
HFT6-34	10 ~ 180s		

Note: The air delayed head is adjusted to the minimum value when leaving the factory.

The air delayed head installation and disassembly are shown in Figure 14 and Figure 15.

During installation:

- ① Slide groove aligned with contactor rail.
- ② Push down until the clip self-locks.

During disassembly:

- ① Clip lifts up.
- ② Push up along the slide groove to remove.

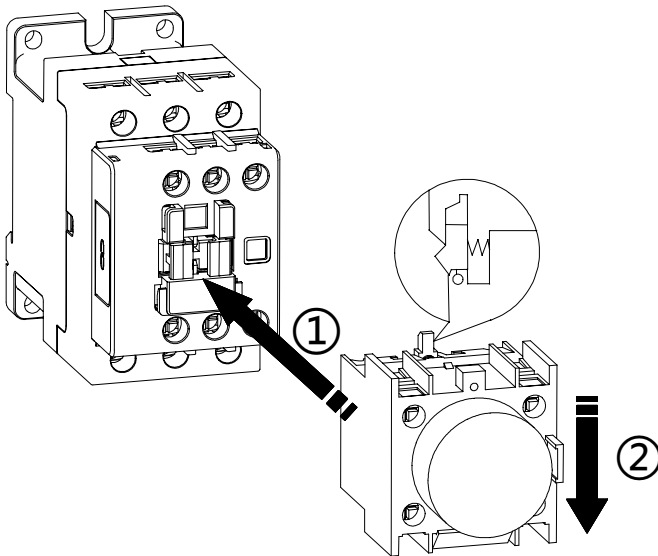

Fig. 14 Air delayed head installation

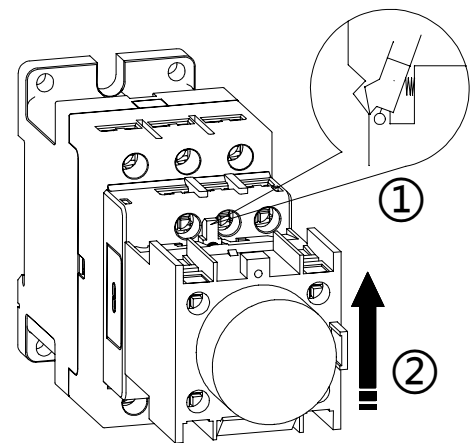

Fig. 15 Air delayed head disassembly

(3) Mechanical interlock module

HFR8-38H installation shows in Figure 16.

During installation:

- ① Use screwdriver to remove the knock hole on the top cover.

- ② Install the HFR8-38H.
- ③ Install another contactor as shown.
- ④ Install fixed circlip.
- ⑤ Install two contactors in place.
- ⑥ Install the upper and lower two fixed parts, fixed on the top cover.

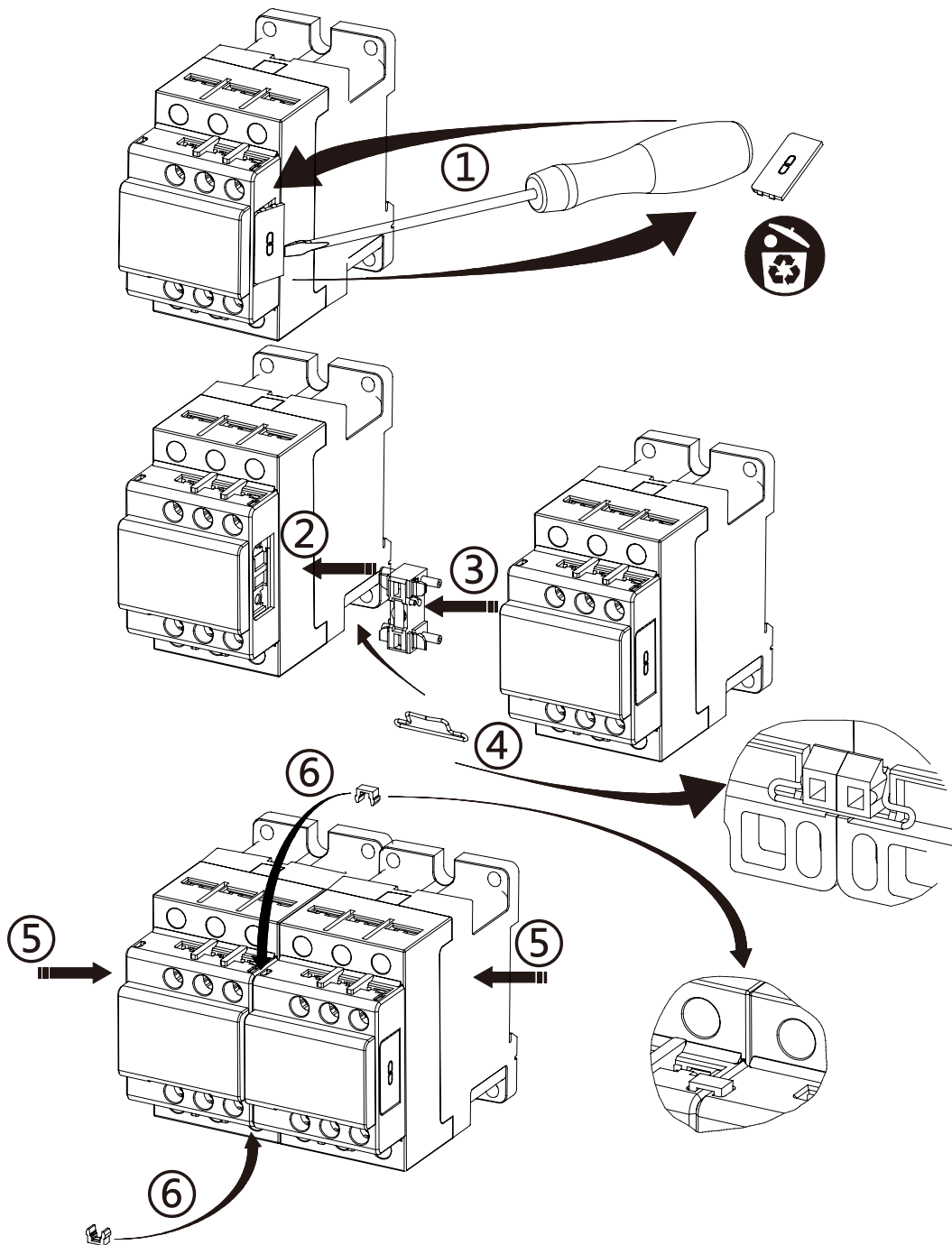

Fig. 16 HFR8-38H accessories installation diagram

HFR8-65H installation shows in Figure 17.

During installation:

- ① Install HFR8-65H.
- ② Install another contactor as shown.
- ③ Install two locks.
- ④ Install two fixed parts.
- ⑤ Install two contactors in place.

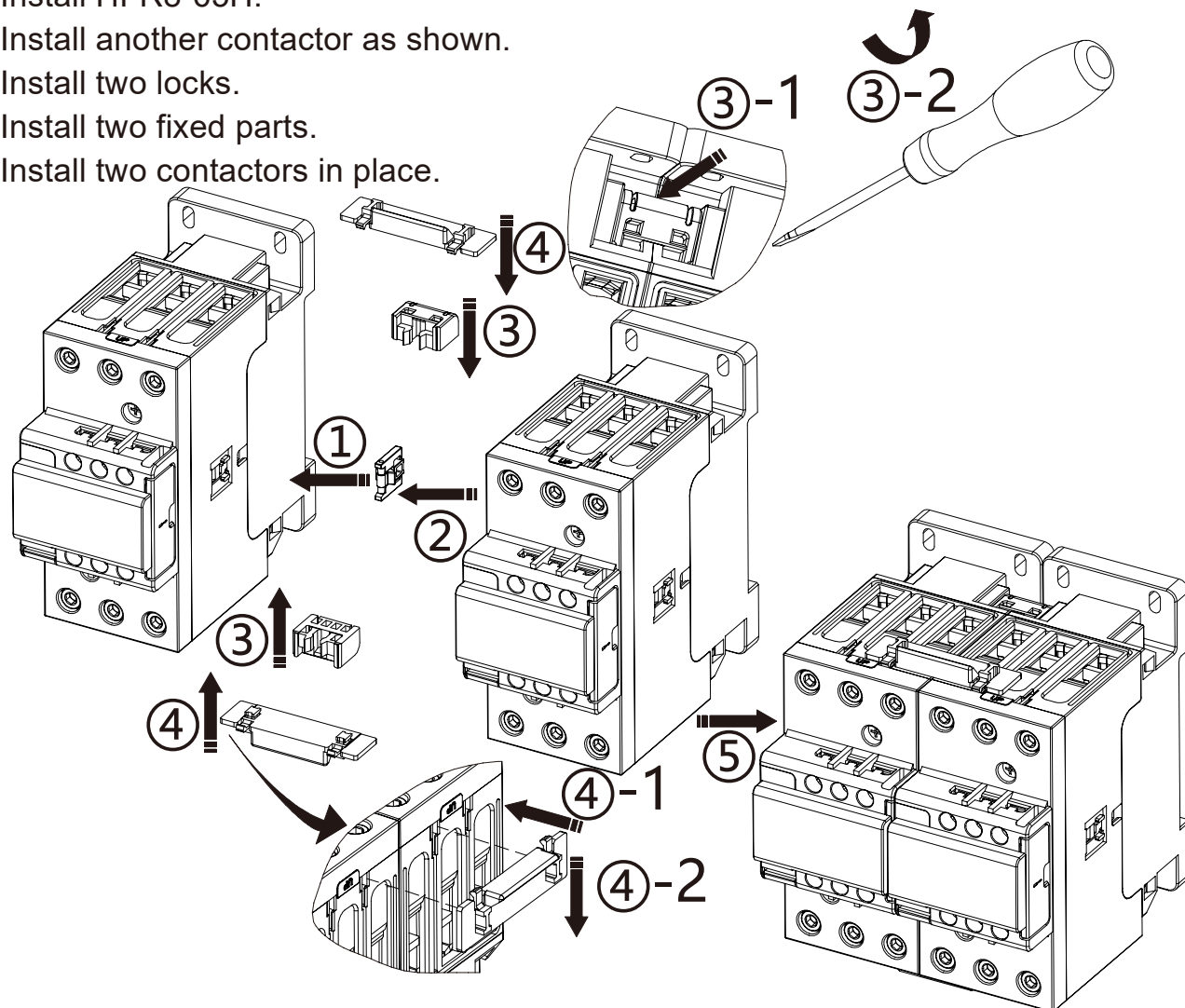

Fig. 17 HFR8-65H and HFR8-95H accessories installation diagram

(4) Electromagnetic starter

The contactor can be combined with the HDRX series thermal overload relay to form an electromagnetic starter.

Test and operation

- Check whether the technical parameters of the product meet the use requirements.
- Firstly, connect the control circuit for no-load test, if there is no abnormality, then connect the load.
- Do not allow anything else to fall into the product.
- Recommended to select SCPD according to category two coordinated protection, rated limiting short-circuit current I_q : 20kA (corresponding test voltage 400V), and the fuse references are shown in Table 8.

Table. 8 Mating fuse category

Model	HDCX-09	HDCX-12	HDCX-18	HDCX-25	HDCX-32	HDCX-38
Main circuit	HRT16-00 20A	HRT16-00 20A	HRT16-00 32A	HRT16-00 40A	HRT16-00 50A	HRT16-00 63A
Model	HDCX-40	HDCX-50	HDCX-65	HDCX-80	HDCX-95	-
Main circuit	HRT16-00 63A	HRT16-00 80A	HRT16-00 80A	NGTC00 100A	NGTC00 125A	-
Auxiliary circuit	HRT16-00 10A					

- Wire cross section and tightening torque are shown in Table 9.

Table. 9 Mating fuse category

Current specification			09/12/18	25/32/38	40/50/65	80/95
Main circuit wiring						
Flexible wire without terminals	1 wire	mm ²	1...4	1.5...10	4...25	6...50
	2 wires	mm ²	1...4	1.5...6	4...16	6...25
Flexible wire with terminals	1 wire	mm ²	1...4	1...6	4...25	6...50
	2 wires	mm ²	1...2.5	1...4	4...10	6...16
Rigid wire without terminals	1 wire	mm ²	1...4	1.5...6	4...25	6...50
	2 wires	mm ²	1...4	1.5...6	4...10	6...25
Tightening torque		N·m	1.2	1.8	5	9
Wiring of control and auxiliary circuits						
Flexible wire without terminals	1 wire	mm ²	1...4			
	2 wires	mm ²				
Flexible wire with terminals	1 wire	mm ²	1...2.5			
	2 wires	mm ²				
Rigid wire without terminals	1 wire	mm ²	1...4			
	2 wires	mm ²				
Tightening torque		N·m	1.2			

Maintenance and care

- Regularly tighten the terminal wiring and remove the deposited dust, otherwise it will cause the danger of fire and short circuit.
- Remove small particles of spattered metal from contactor contacts or arc shields and discontinue use when contact surfaces are burned to the point of exposing base material.

Fault analysis and treatment

The common faults analysis and solution are listed in Table 10.

Table. 10 Common fault analysis and treatment

Fault	Cause	Solution
The core does not close or has insufficient suction (contacts are closed but the core is not fully drawn).	<ol style="list-style-type: none"> 1.The power supply voltage is too low or has too large fluctuation; 2.The operating circuit has an insufficient power supply capacity or the wiring is disconnected, there is a wiring error, and the control contact is poorly connected; 3.The technical parameters of the coil are inconsistent with the working conditions; 4.The product itself is damaged (Such as, coil disconnected or burned, and mechanical movable part blocked, etc.). 	<ol style="list-style-type: none"> 1.Increase the power supply voltage; 2.Increase the power capacity, replace the circuit, and repair the control contacts; 3.Replace the contactor; 4.Eliminate blocking faults and repair damage parts.
No release or slowly release	<ol style="list-style-type: none"> 1.Contact fusion welding; 2.The mechanical movable part is stuck; 3.Iron core pole surface has oil or dust. 	<ol style="list-style-type: none"> 1.Eliminate fusion welding faults, repair or replace contactors; 2.Solve the stuck fault; 3.Clean the pole face of the iron core.
The core is overheated or burned	<ol style="list-style-type: none"> 1.The power supply voltage is too high or too low; 2.The technical parameters (such as rated voltage, frequency, power-on duration rate and applicable working system) of the coil are inconsistent with the actual use conditions; 3.The mechanical movable part is stuck; 4.The pole surface of the iron core is uneven or is attached with dust. 	<ol style="list-style-type: none"> 1.Adjust the power supply voltage to 0.85U_c to 1.1U_c; 2.Replace the contactor; 3.Solve the stuck fault; 4.Clean the pole face of the iron core.
Contact fusion welding	<ol style="list-style-type: none"> 1.The operating frequency is too high or the product is overloaded; 2.Short circuit on the load side. 	<ol style="list-style-type: none"> 1.Replaces by the appropriate contactor; 2.Eliminate short circuit fault.

HIMEL

www.himel.com

Copyright@Himel Co., Ltd.

 Paper can be recycled

Jul. 2025