



HDQ1S Automatic Transfer Switch

Catalogue 2025



Contents

Performance	2
Features.....	3
Order information.....	4
Selection Code.....	4
Controller function.....	5
HDQ1S PC Class ATS Controller function.....	5
Technical parameter.....	6
HDQ1S PC Class ATS Specification.....	6
Controller terminal.....	8
P type controller terminal.....	8
G type controller terminal.....	10
D type controller terminal.....	12
Wiring diagram and installation direction.....	14
Main circuit wiring diagram.....	14
Installation direction.....	14
Installation instructions and time.....	15
Installation instruction.....	15
Safety distance.....	15
Dimensional parameters.....	16
Cutout Dimensions for Split Controller.....	16
Product diagram.....	16
Diagram and operation.....	17
Manual operation.....	17
Controller Parameter Settings.....	18
G type Controller parameter setting.....	18
D type Controller parameter setting.....	20
Transmission logic.....	22
P type ATSE transfer logic.....	22
G & D type ATSE transfer logic.....	22
Dimensions and connections.....	24
Dimensions and connections.....	24



Control & Power Coordination

- Support **Manual / Automatic / Remote** control mode, flexible for operation needs.
- **Build-in Generator control**, linkable with generator system, auto generator start and stop.



Scenario Adaptation & Installation Optimization

- **Adjustable voltage protection**: Customize over/under-voltage thresholds for Power / Generator / Solar and other source, adapting to complex grid conditions.
- Optimized wiring: **"2 incoming lines + 1 outgoing line"** reduces redundancy; optional **Top / Bottom entry** fits different cabinet layouts.



Safety Protection & Compliance

- Dual locking: Full series with **mechanical padlock** + **electrical key lock**, preventing unauthorized operation.
- Controller protection: **Built-in fuses** (plug-and-play for quick replacement, minimizing downtime)
- Global certifications: **CE / CB / RoHS**, meeting multi-region market access.



Low Consumption & Smart O&M

- **Energy-saving**: Drive motor works only during switching (zero standby power); low-impedance main circuit reduces power loss.
- Utilization Category: AC-32B @ **3200A**.
- Smart connectivity: **RS485** interface for remote monitoring, fault alarm & data collection (cuts inspection costs).



Standards

- IEC 60947-1
- IEC 60947-6-1
- GB/T 14048.11



Certifications

- CE Certification
- CB Certification
- CCC Certification



Operating conditions

- Ambient temperature $-25^{\circ}\text{C} \sim +70^{\circ}\text{C}$, relative humidity $\leq 90\%$
- The altitude of the installation site does not exceed 2,000m
- Storage temperature: $-35^{\circ}\text{C} \sim +80^{\circ}\text{C}$



Electromagnetic compatibility (EMC)

- Electrostatic Discharge (ESD) Air discharge: Level 3
Contact discharge: Level 2
- Radio-Frequency (RF) Electromagnetic Field Level 3
- Electrical Fast Transient/Burst (EFT/Burst) Level 3
- Surge (Impact) Level 3
- Harmonics Level 3
- Radiation level Level A



Pollution degree

- Pollution degree 3



Switch Class

- Class PC



■ Selection Code

Series	Frame size	Poles	Rated Current	Controller	Line/load
HDQ1S	0100:100AF	2:2P	0032/0063/0080/0100	P: Integrated controller w/o screen G: Integrated controller with LED screen D: Split controller with LCD screen & RS485	U: Top entry D: Bottom entry
	0160:160AF	3:3P	0125/0160		
	0250:250AF	4:4P	0200/0250		
	0800:800AF		0315/0400 0500/0630 800		
	1600:1600AF	3:3P 4:4P	0800/1000/ 1250 1600 2000		
	3200:3200AF		2500 3200		

G Type can be optionally equipped with RS485 communication. Please contact the manufacturer.

HDQ1S P type

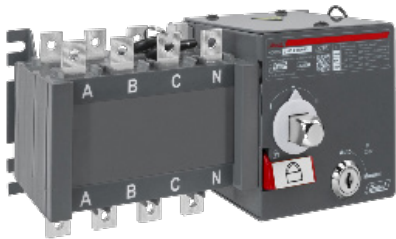

- Auto + Remote + Manual Control
- Mechanical padlock + electrical key lock
- Override controls and force switch to zero (off) position
- Source available indication
- Integrated position auxiliary contacts (I – O – II)
- Manual Emergency Operation with external handle

HDQ1S G type

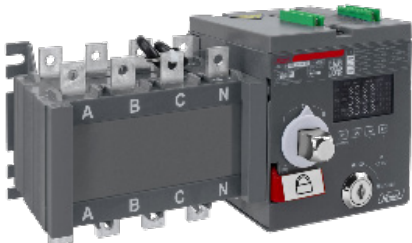

- Auto + Manual + Generator Control
- Adjustable Voltage protection
- Mechanical padlock + electrical key lock
- Override controls and force switch to zero (off) position
- Source available indication
- Integrated position auxiliary contacts (I – O – II)
- Manual Emergency Operation with external handle

HDQ1S D type

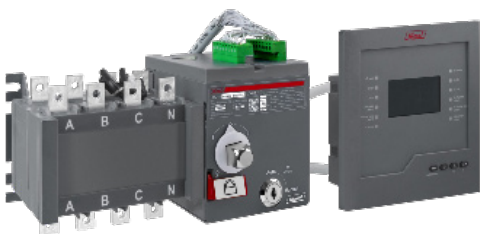

- Auto + Manual + Generator Control
- Communication RS485
- Adjustable Voltage protection
- Mechanical padlock + electrical key lock
- Override controls and force switch to zero (off) position
- Source available indication
- Integrated position auxiliary contacts (I – O – II)
- Manual Emergency Operation with external handle

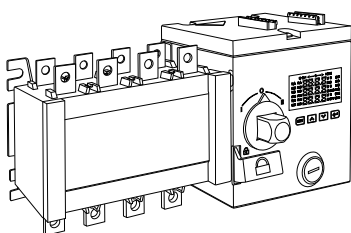

Top entry

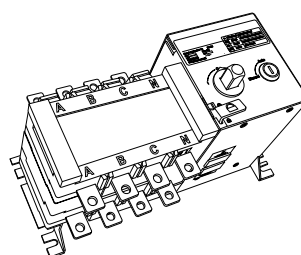

Bottom entry



Controller function

■ HDQ1S PC Class ATS Controller function

■ : Standard □ : Optional –: Without

Function\Controller	P	G	D
Controller Location	Integrated	Integrated	Split
Display Mode	–	LED	LCD
Manual Handle Operation	■	■	■
Auto. Transfer and recover	■	■	■
Auto. Transfer and without recover	–	■	■
Auto. Transfer and each as backup	–	■	■
Remote Control	■	–	■ (RS485)
Communication (RS485)	–	–	■
Baud Rate	–	–	(1200/2400 4800/9600)
Power to Power	■	■	■
Power to Generator	–	■	■
Normal source phase failure monitoring	■	■	■
Normal source voltage loss monitoring	■	■	■
Alternative Source phase failure monitoring	–	■	■
Alternative Source voltage loss monitoring	■	■	■
Fire OFF	■ (Passive Signal)	■ (DC24V Signal)	■ (DC24V Signal)
Fire OFF Signal	–	■ (Passive Signal)	■ (Passive Signal)
Transfer delay time adjustable	–	■	■
Return delay time adjustable	–	■	■
Normal and Alternative source state output	■	■	■
Normal and Alternative source ON state output	■	■	■
Normal and Alternative source state LED Indication	■	■	■
Normal and Alternative source ON state LED Indication	–	■	■
Controller Fuse	■	■	■
Over-Voltage and Under-Voltage state output	–	■	■
Over-Frequency Protection	–	–	■
Under-Frequency Protection	–	–	■
Phase sequence protection	–	–	■
Alarm signal Output	–	–	■
Transfer Failure Alarm	–	–	■
Fault records/queries	–	–	■
Manual/Auto Switch	■	■	■



■ HDQ1S PC Class ATS Specification

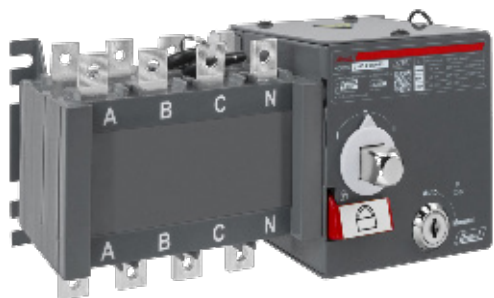

32 to 250A		Frame size
Rated voltage		Utilisation category
415 VAC		AC-32B
415 VAC		AC-33iB
415 VAC		AC-33B
Number of poles		
Operating positions		
Control types		
Electrical features		
Rated insulation voltage U_i (V)		
Rated impulse withstand voltage U_{imp} (kV)		
Rated voltage U_e (V)	2P	
	3/4P	
Rated frequency (Hz)		
Rated Short-Time Withstand Current I_{cw} (kA)		
Rated Short-Circuit Making Capacity I_{cm} (kA)		
Mechanical life (cycles)		
Conversion time		
Certificates		
Applicable standard		
Equipment Class		
Pollution Level		
Dimensions		
Dimension (WxHxD)* *without handle	2P	
	3P	
	4P	



Technical parameter

100AF				160AF		250AF	
Rate operational currents Ie(A) according to IEC 60947-6-1 & GB/T 14048.11							
32	63	80	100	125	160	200	250
32	63	80	100	125	160	200	250
32	63	63	63	125	125	125	125
2P/3P/4P							
I-O-II							
P、G、D							
800							
8							
230V							
400V							
50/60							
5				10			
7.65				17			
10000				10000		8000	
≤ 3s							
CE/CB							
IEC 60947-6-1 / GB/T 14048.11							
PC class							
Operate in Pollution Level III environments							
233x118x141				268x126x191		312x176x210	
233x118x141				268x126x191		312x176x210	
243x116x141				306x146x193		370x164x195	



■ HDQ1S PC Class ATS Specification

315 to 3200A		Frame size
Rated voltage		Utilisation category
415 VAC		AC-32B
415 VAC		AC-33iB
415 VAC		AC-33B
Number of poles		
Operating positions		
Control types		
Electrical features		
Rated insulation voltage U_i (V)		
Rated impulse withstand voltage U_{imp} (kV)		
Rated voltage U_e (V)		3/4P
Rated frequency (Hz)		
Rated Short-Time Withstand Current I_{cw} (kA)		
Rated Short-Circuit Making Capacity I_{cm} (kA)		
Mechanical life (cycles)		
Conversion time		
Certificates		
Applicable standard		
Equipment Class		
Pollution Level		
Dimensions		
Dimension (WxHxD)* *without handle		3P
		4P



Technical parameter

800AF				1600AF				3200AF			
Rate operational currents Ie(A) according to IEC 60947-6-1 & GB/T 14048.11											
315	400	500	630	800	800	1000	1250	1600	2000	2500	3200
315	400	500	630	630	800	1000	1250	1600	2000	2500	3200
160	200	250	315	315	400	500	630	800	1000	1250	1600
3P/4P											
I-O-II											
P、G、D											
800						1000					
8						12					
400V											
50/60											
16				32				50			
32				67.2				105			
3000				3000				2000			
≤ 3s											
CE/CB											
IEC 60947-6-1 / GB/T 14048.11											
PC class											
Operate in Pollution Level III environments											
375x287x367				520x370x325				540x440x505			
435x287x367				635x370x325				640x440x505			

Controller terminal



■ P type controller terminal

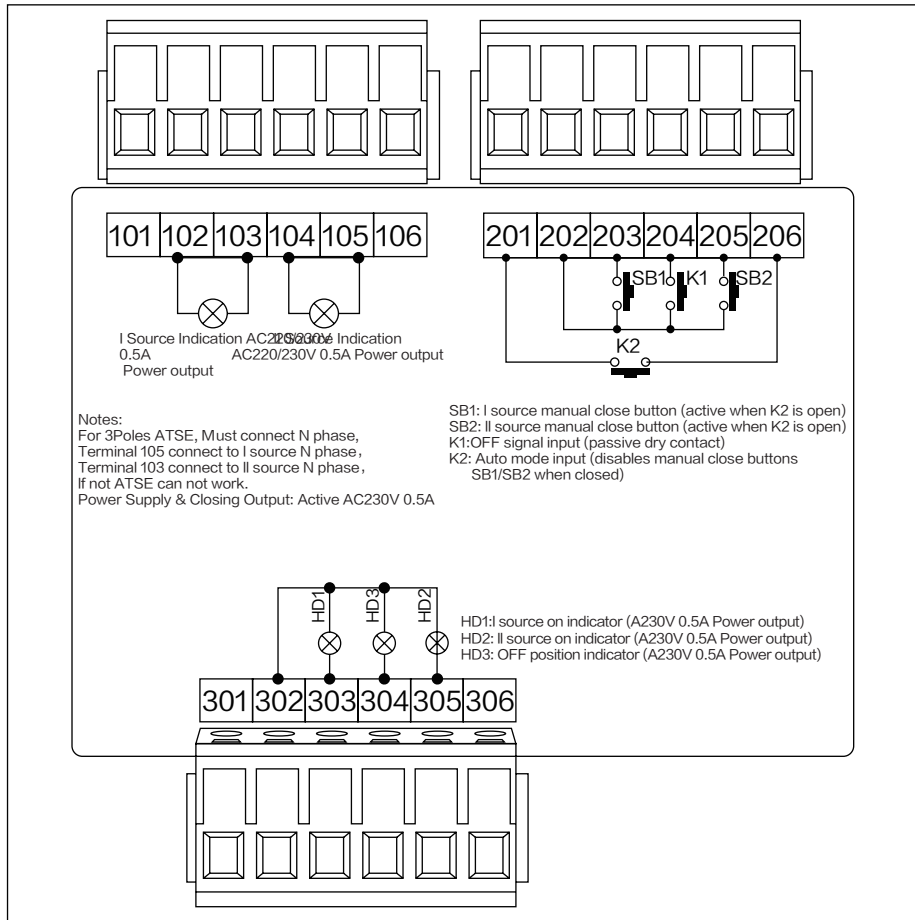

100 P type

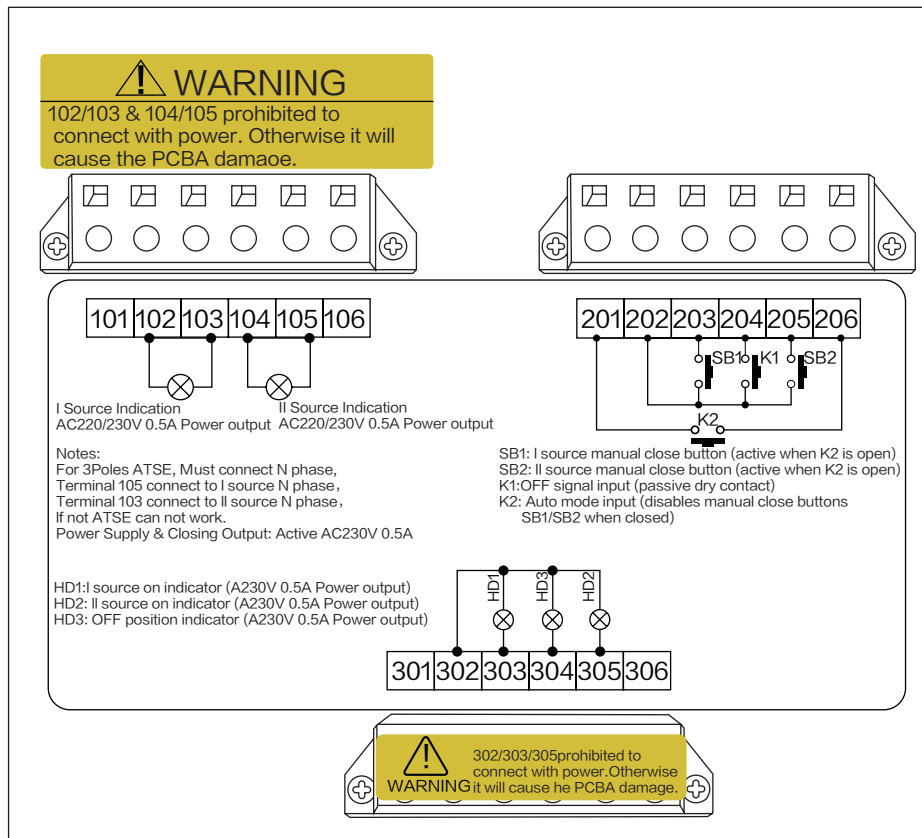

160~3200 P type



Controller terminal

Denomination	Terminal	Description	Characteristics	Recommended Cable Section
ATS Power status output	101	Unused terminal, no operational purpose		
	102	Source II Indication if closed with 103	AC230V 0.5A Power output	1.5–2.5mm ²
	103	Source II N Poles for 3P ATS	AC230V 0.5A Power output	1.5–2.5mm ²
	104	Source I Indication if closed with 105	AC230V 0.5A Power output	1.5–2.5mm ²
	105	Source I N Poles for 3P ATS	AC230V 0.5A Power output	1.5–2.5mm ²
	106	Unused terminal, no operational purpose		
ATS Control Input	201	Default connected to 206 and operates in Auto mode, if cancel the connect, ATS will enter Remote Control mode	Dry Contacts	1.5–2.5mm ²
	202	Common control terminal for 203–205	Dry Contacts	1.5–2.5mm ²
	203	Position I order if closed with 202 (only works when 201–206 unconnected)	Dry Contacts	1.5–2.5mm ²
	204	Position OFF order if closed with 202	Dry Contacts	1.5–2.5mm ²
	205	Position II order if closed with 202 (only works when 201–206 unconnected)	Dry Contacts	1.5–2.5mm ²
	206	Default connected to 201 and operates in Auto mode, if cancel the connect, ATS will enter Remote Control mode	Dry Contacts	1.5–2.5mm ²
ATS Output Contacts	301	Unused terminal, no operational purpose		
	302	Common control terminal for 303–305	AC230V 0.5A Power output	1.5–2.5mm ²
	303	Aux contact position I (Normally open contact)	AC230V 0.5A Power output	1.5–2.5mm ²
	304	Aux contact position OFF (Normally open contact)	AC230V 0.5A Power output	1.5–2.5mm ²
	305	Aux contact position II (Normally open contact)	AC230V 0.5A Power output	1.5–2.5mm ²
	306	Unused terminal, no operational purpose		

Controller terminal



■ G type controller terminal

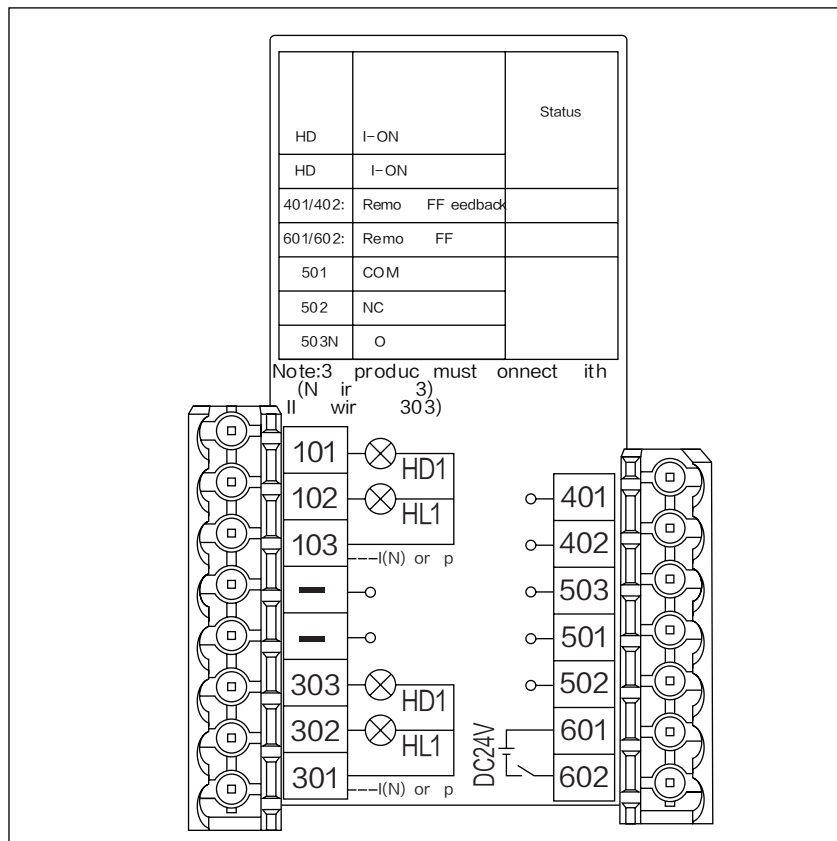

100~250AF G type

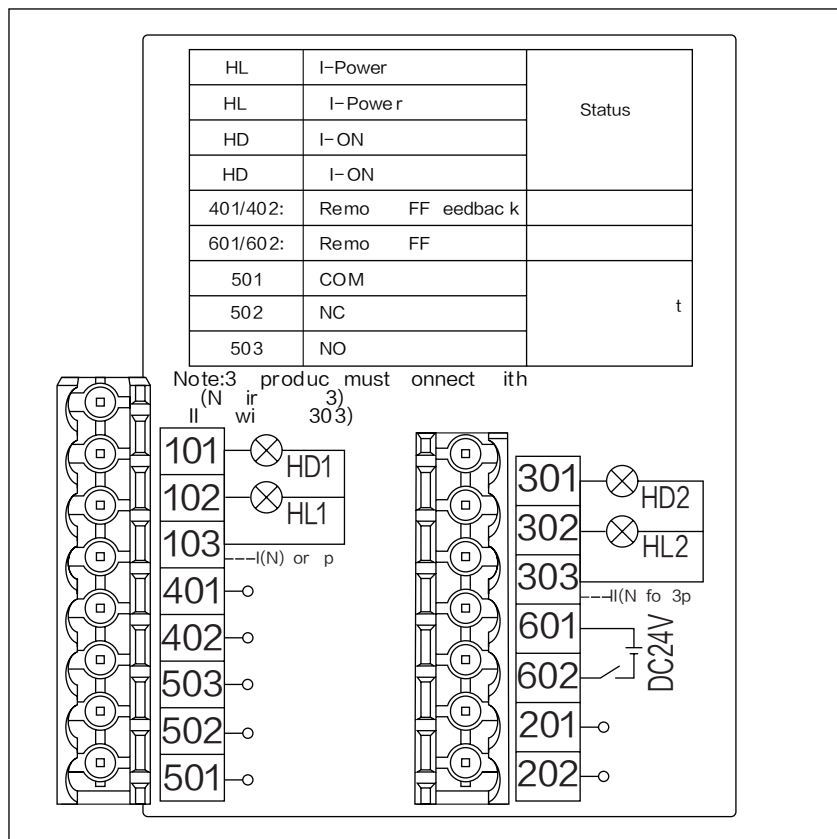

800~3200AF G type



Controller terminal

Denomination	Terminal	Description	Characteristics	Recommended Cable Section
ATS Power status I output	101	Source I power-on (Normally open contact)	AC230V 0.5A Power output	1.5–2.5mm ²
	102	Source I availability (Normally open contact)	AC230V 0.5A Power output	1.5–2.5mm ²
	103	Common control terminal for 101–102 & source I N poles for 3Poles ATS	AC230V 0.5A Power output	1.5–2.5mm ²
MODBUS Module (Optional)	201	B-: RS485 MODBUS communication module terminal, Disabled.	1200/24004800/9600	
	202	A+: RS485 MODBUS communication module terminal, Disabled.		
ATS Power status II output	301	Source II power-on (Normally open contact)	AC230V 0.5A Power output	1.5–2.5mm ²
	302	Source II availability (Normally open contact)	AC230V 0.5A Power output	1.5–2.5mm ²
	303	Common control terminal for 101–102 & source II N poles for 3Poles ATS	AC230V 0.5A Power output	1.5–2.5mm ²
Fire OFF signal feedback output	401	Aux contact position OFF, closed with 402 (Normally open contact)	Dry Contacts	1.5–2.5mm ²
	402	Aux contact position OFF, closed with 401 (Normally open contact)	Dry Contacts	1.5–2.5mm ²
Generator Start/ Stop signal(Default disabled, Can be turn on by controller)	501	Common terminal for 503–503	Dry Contacts	1.5–2.5mm ²
	502	NC contact.(501/502), when Generator function Open, NO contact.(501/502)	Dry Contacts	1.5–2.5mm ²
	503	NO contact.(501/503), when Generator function Open, NC contact.(501/503)	Dry Contacts	1.5–2.5mm ²
Fire OFF signal input	601	Fire OFF signal, position OFF order if closed with 602	DC24V	1.5–2.5mm ²
	602	Fire OFF signal, position OFF order if closed with 601	DC24V	1.5–2.5mm ²

Controller terminal



■ D type controller terminal

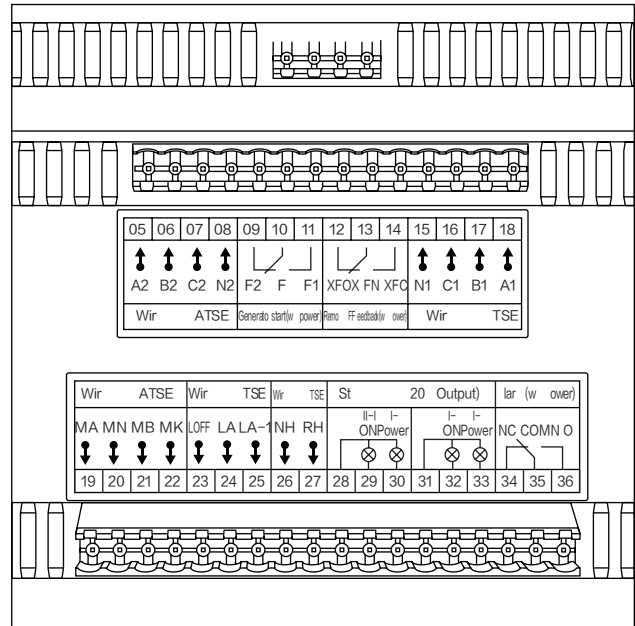
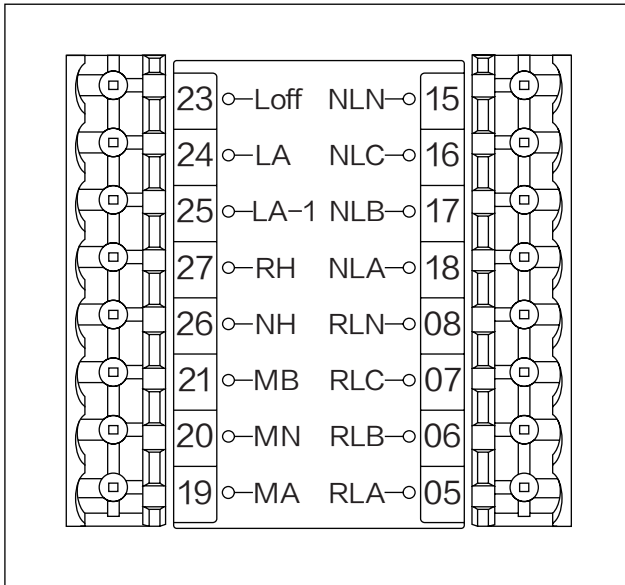

100-250AF D type

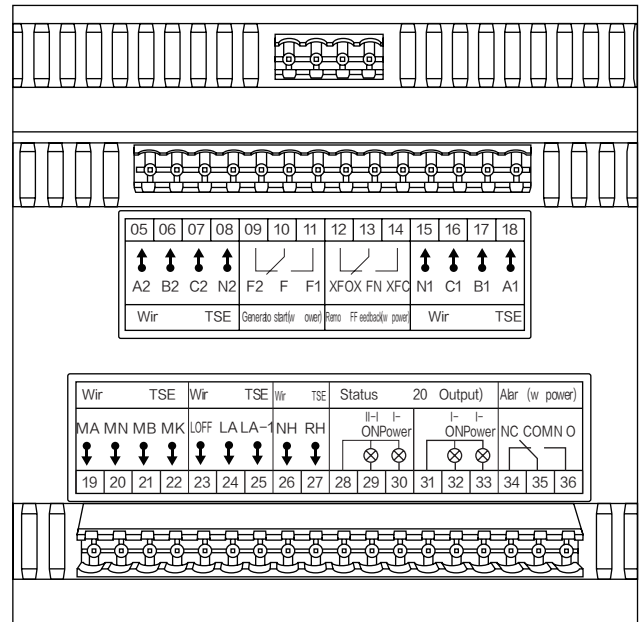
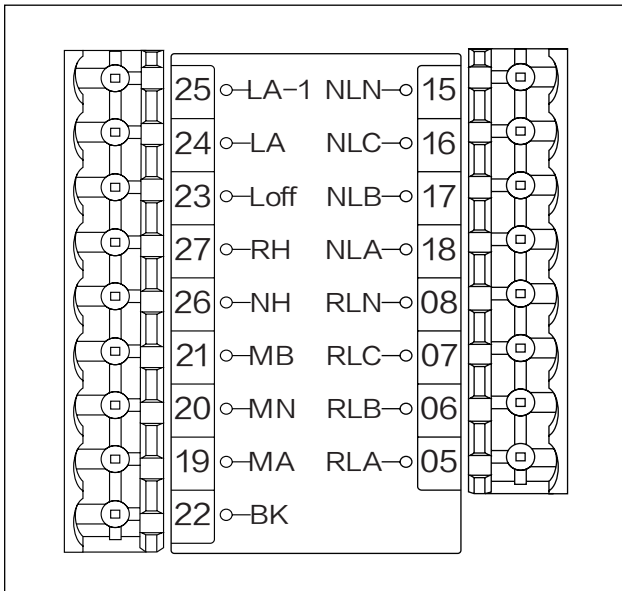

800-3200AF D type



Controller terminal

Denominatio	Terminal	Description	Characteristics	Recommended Cable Section
Fire OFF signal input	01	Fire OFF signal, position OFF order if closed with 02	DC24V	1.5–2.5mm ²
	02	Fire OFF signal, position OFF order if closed with 01	DC24V	1.5–2.5mm ²
MODBUS Module	03	A+: RS485 MODBUS communication module terminals, Default disabled	1200/24004800/9600	1.5–2.5mm ²
	04	B-: RS485 MODBUS communication module terminals, Default disabled		1.5–2.5mm ²
ATS source II Input	05	Source II, Phase A input	(Connect with the ATS body by Connect Cable)	
	06	Source II, Phase B input		
	07	Source II, Phase C input		
	08	Source II, Phase N input		
Generator Start/ Stop signal(Default distabled, Can be turn on by controller)	09	NC contact.(09/10), when Generator function Open, NO contact.(09/10)	Dry Contacts	1.5–2.5mm ²
	10	Common control terminal for 09 & 11	Dry Contacts	1.5–2.5mm ²
	11	NO contact.(11/10), when Generator function Open, NC contact.(11/10)	Dry Contacts	1.5–2.5mm ²
Fire OFF singal feedback output	12	Aux contact, NO contact.(12/13)	Dry Contacts	1.5–2.5mm ²
	13	Common control terminal for 12 & 14	Dry Contacts	1.5–2.5mm ²
	14	Aux contact, NC contact.(14/13)	Dry Contacts	1.5–2.5mm ²
ATS source I Input	15	Source I, Phase N input	(Connect the ATS body by Connect Cable)	
	16	Source I, Phase C input		
	17	Source I, Phase B input		
	18	Source I, Phase A input		
Motorisation Module Control Inputs	19–22	Terminals 19–22 are used to control and drive the ATS motorization Module.		
Function Mode Interface (Limit Switch & OFF position)	23	Terminals 23–25 are used to transmit the limit switch & OFF position signal from ATS body to controller		
	24			
	25			
ATS source I & II ON	26	Terminals 26–27 are used to monitor the source I & source II ON status		
	27			
ATS Power status II output	28	Common control terminal for 29 & 30	AC230V 0.5A Power output	1.5–2.5mm ²
	29	Source II power-on (Normally open contact)	AC230V 0.5A Power output	1.5–2.5mm ²
	30	Source II availability (Normallyopen contact)	AC230V 0.5A Power output	1.5–2.5mm ²
ATS Power status I output	31	Common control terminal for 32 & 33	AC230V 0.5A Power output	1.5–2.5mm ²
	32	Source I power-on (Normally open contact)	AC230V 0.5A Power output	1.5–2.5mm ²
	33	Source I availability (Normallyopen contact)	AC230V 0.5A Power output	1.5–2.5mm ²
Alarm signal output	34	Aux contact, NC contact.(34/35)	Dry Contacts	1.5–2.5mm ²
	35	Common control terminal for 34 & 36	Dry Contacts	1.5–2.5mm ²
	36	Aux contact, NO contact.(36/35)	Dry Contacts	1.5–2.5mm ²

Wiring diagram and installation direction



■ Main circuit wiring diagram

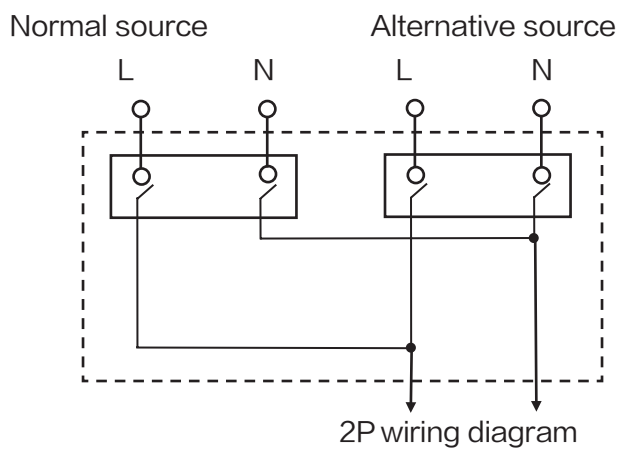
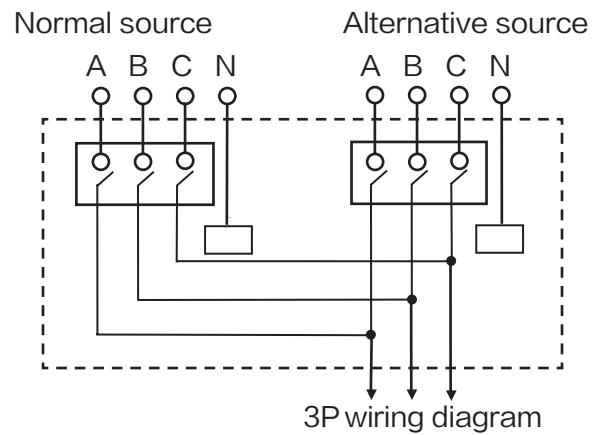
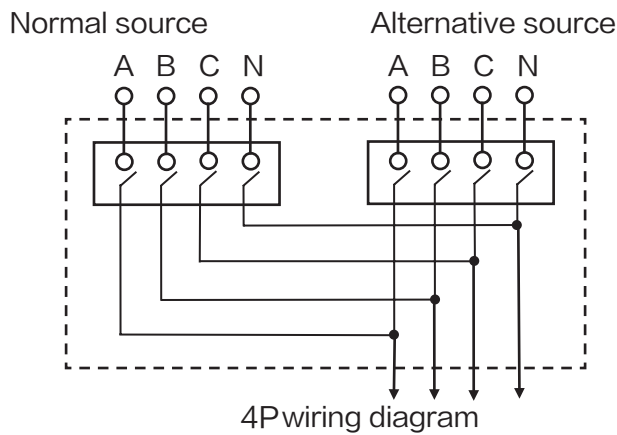

3P ATSE

- P type : Normal source N poles connect with terminal 105, Alternative source 103
- G type: Normal source N poles connect with terminal 103, Alternative source 303
- D type: Normal source N poles connect with terminal 15, Alternative source 08

Note: 2-pole (2P) products are not available for circuit breaker frames rated above 250A

Figure 3 Product Wiring Diagram

■ Installation direction

Recommended orientation

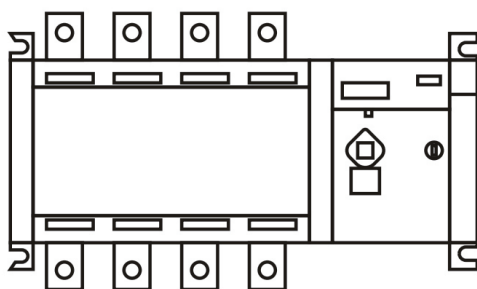

OK

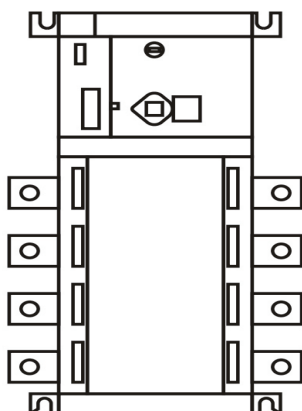

OK

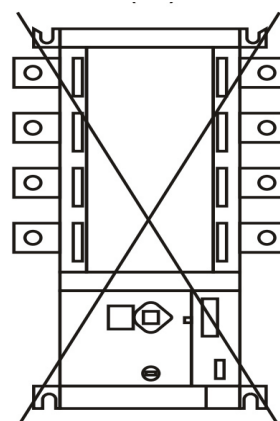
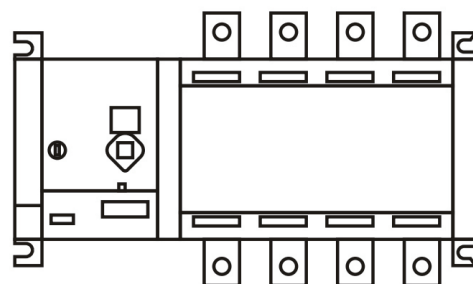



Installation instructions and time

■ Installation instruction

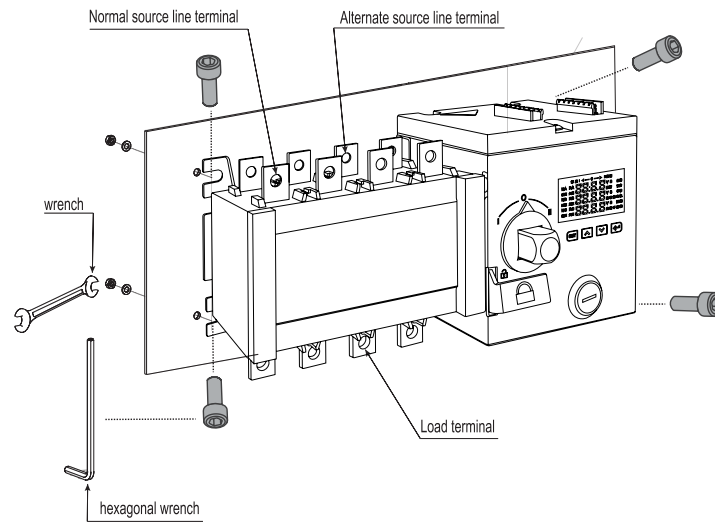
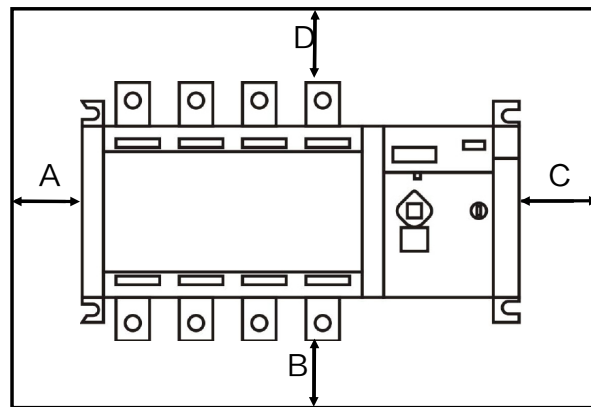

Figure 5 HDQ1S 100~3200 Normal Power, Alternative Power, Outgoing Side Wiring and Product Installation

■ Safety distance



	A	B	C	D
100	0	40	0	40
160	0	55	0	55
250	0	55	0	55
800	0	85	0	70
1600	0	120	0	80
3200	0	130	0	130

Dimensional parameters



■ Cutout Dimensions for Split Controller

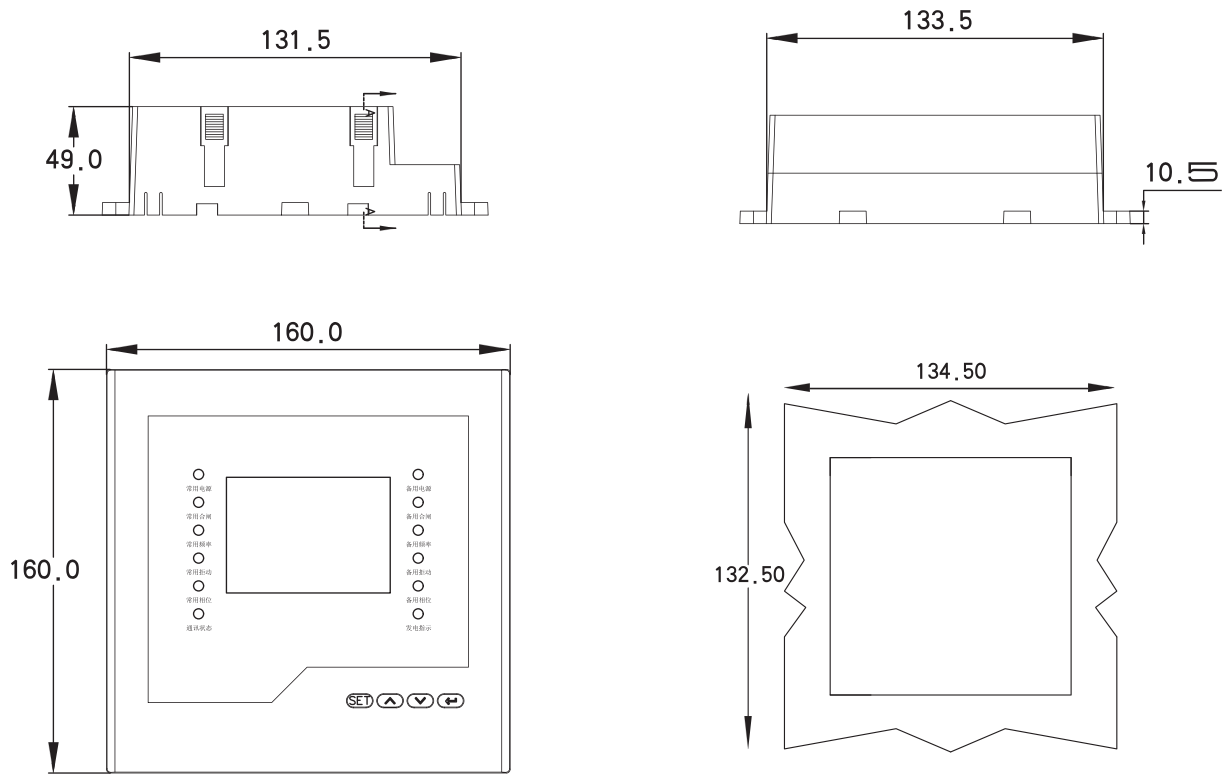

■ Product diagram

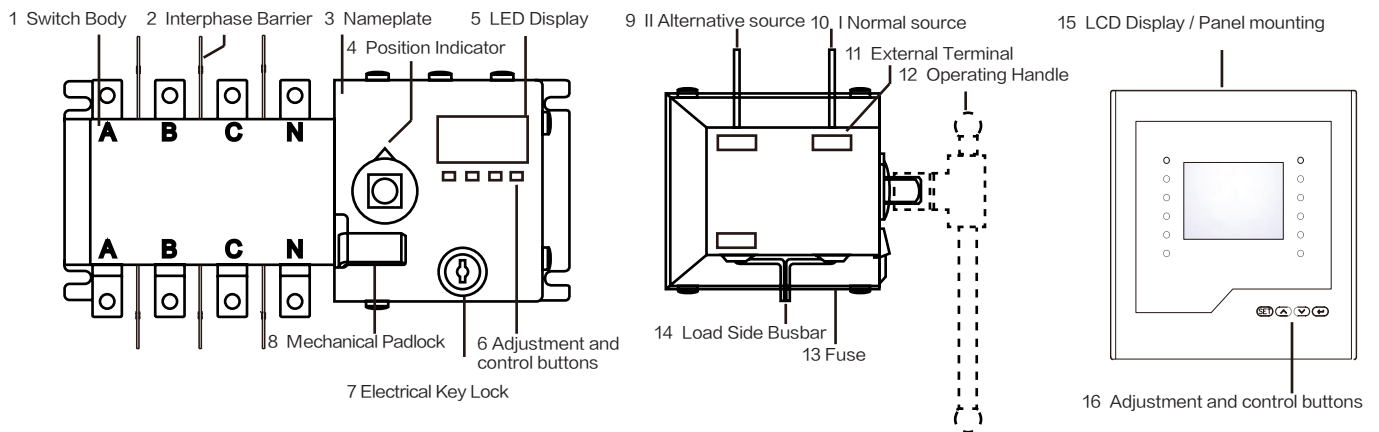

ATSE

Figure 1 Schematic Diagram of the TSE



Diagram and operation

Manual operation

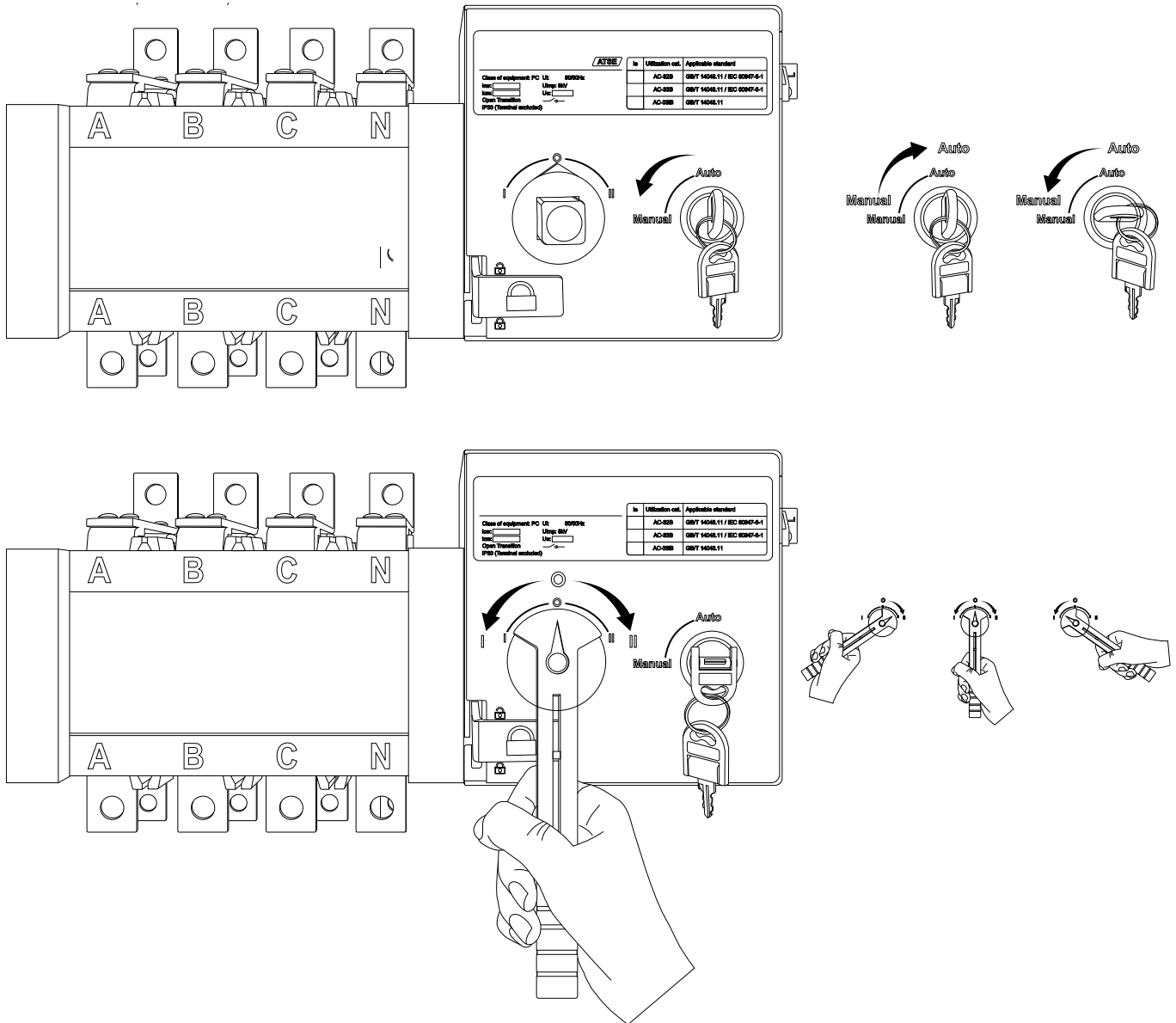

Controller Parameter Settings



■ G type Controller parameter setting

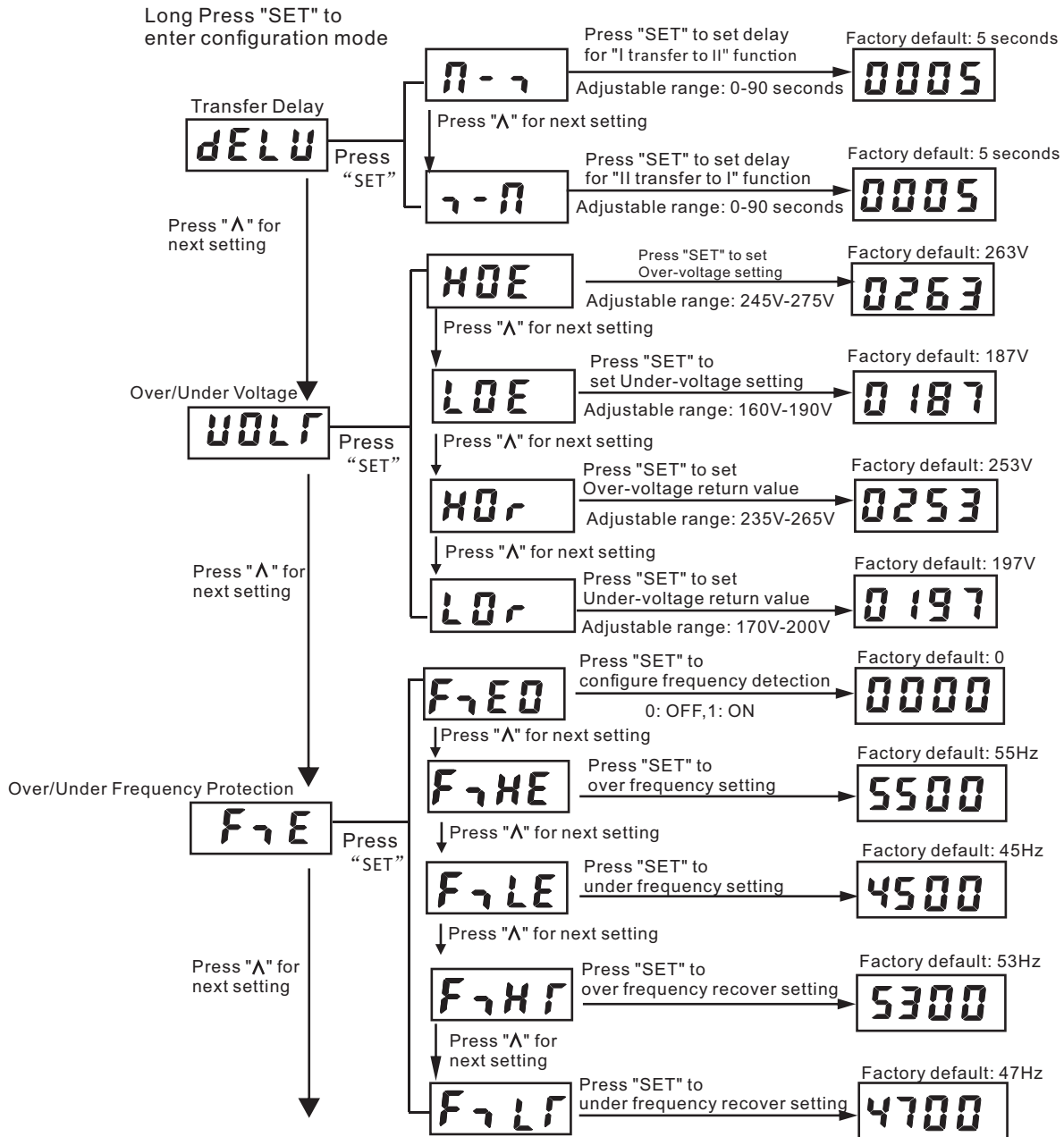



Controller Parameter Settings

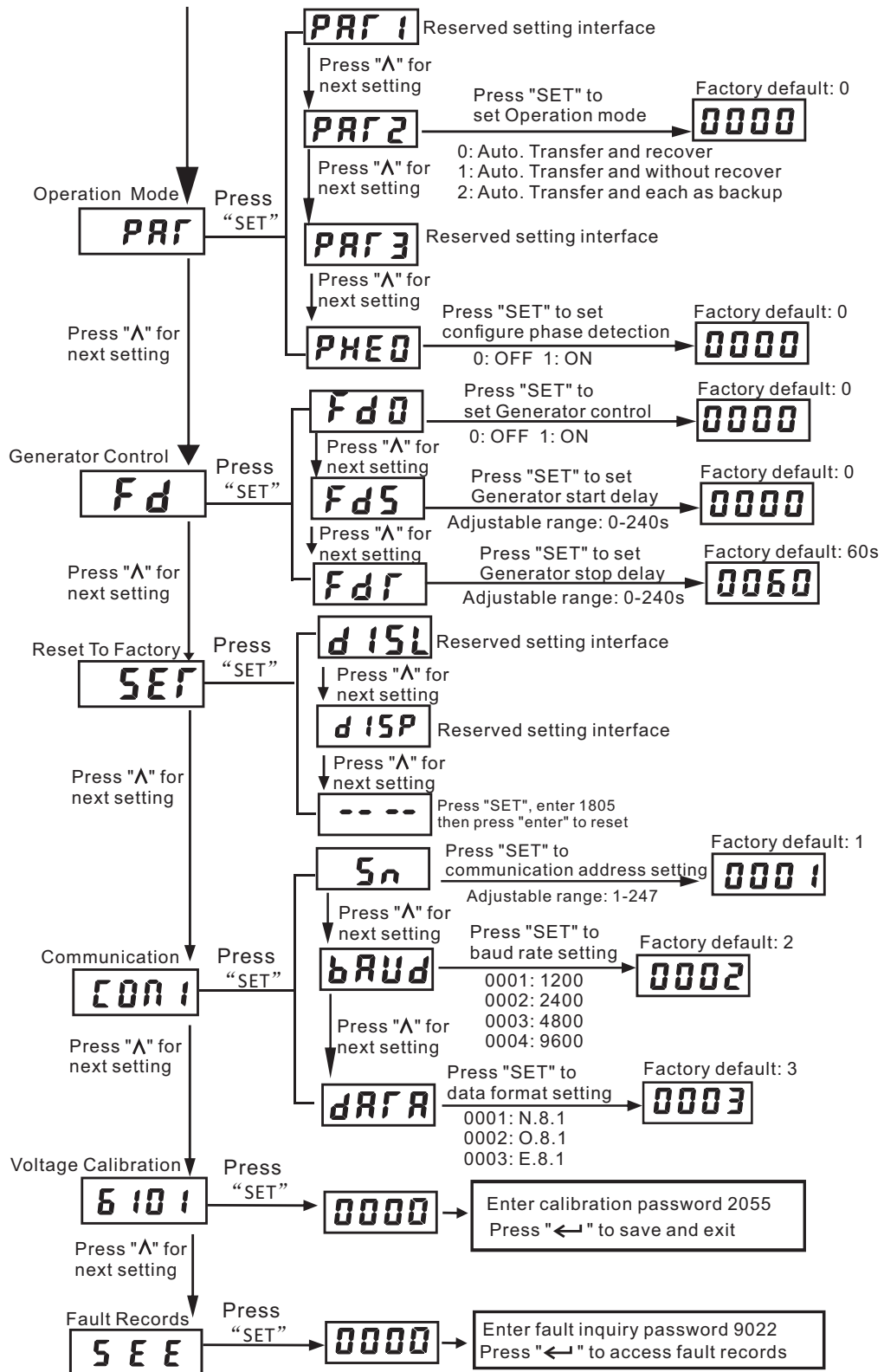

Controller Parameter Settings



■ D type Controller parameter setting

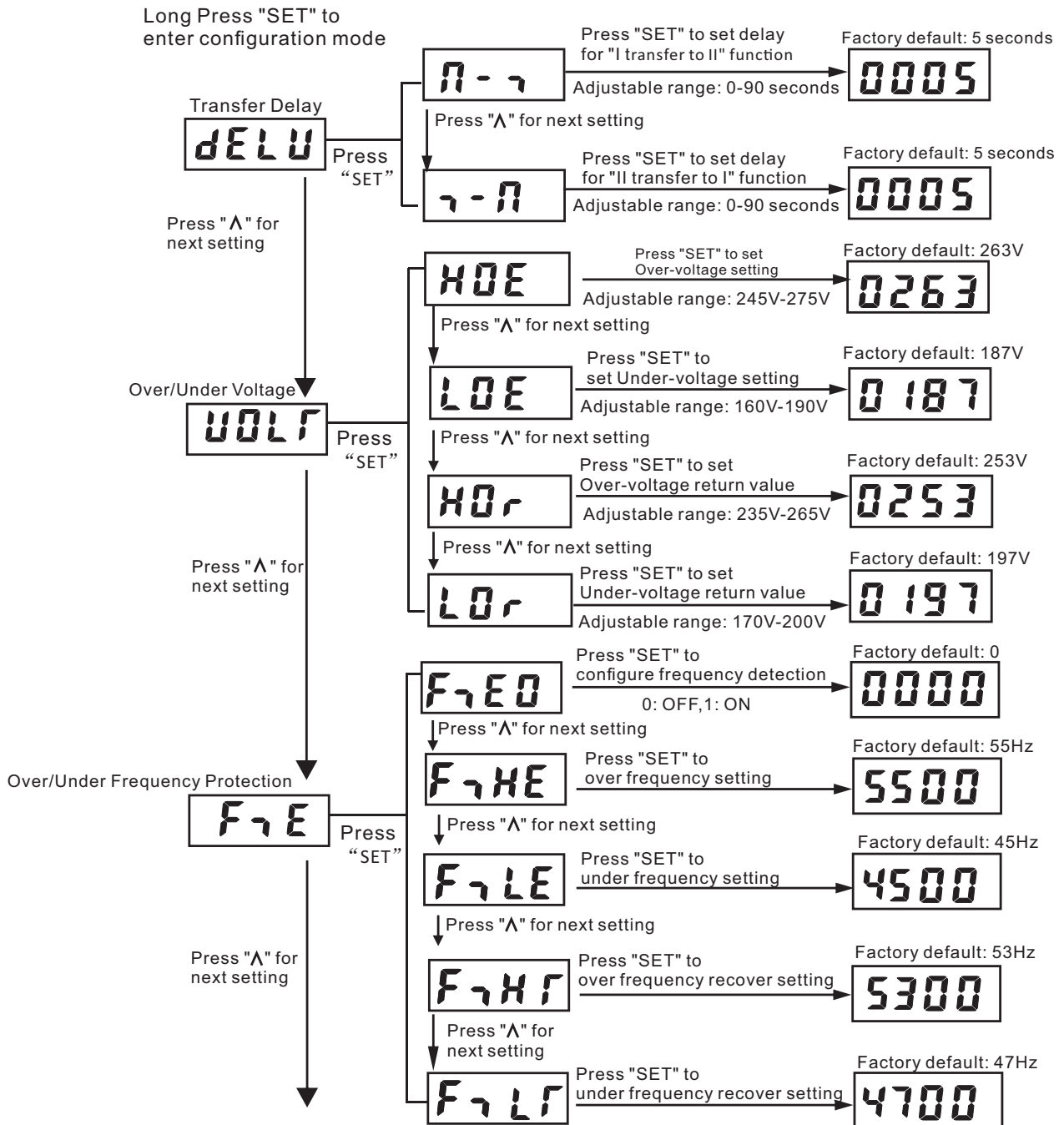



Controller Parameter Settings

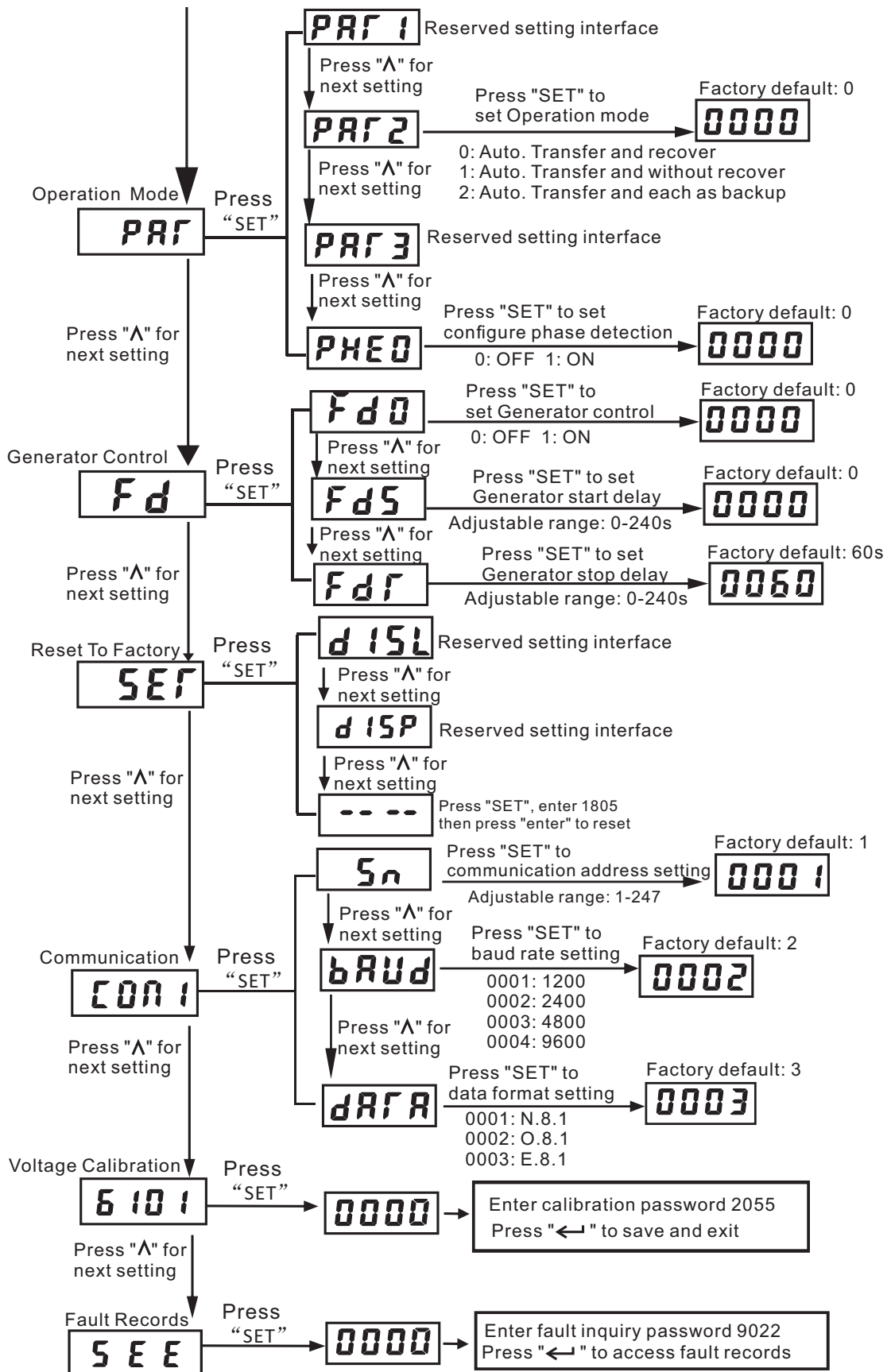



■ P type ATSE transfer logic

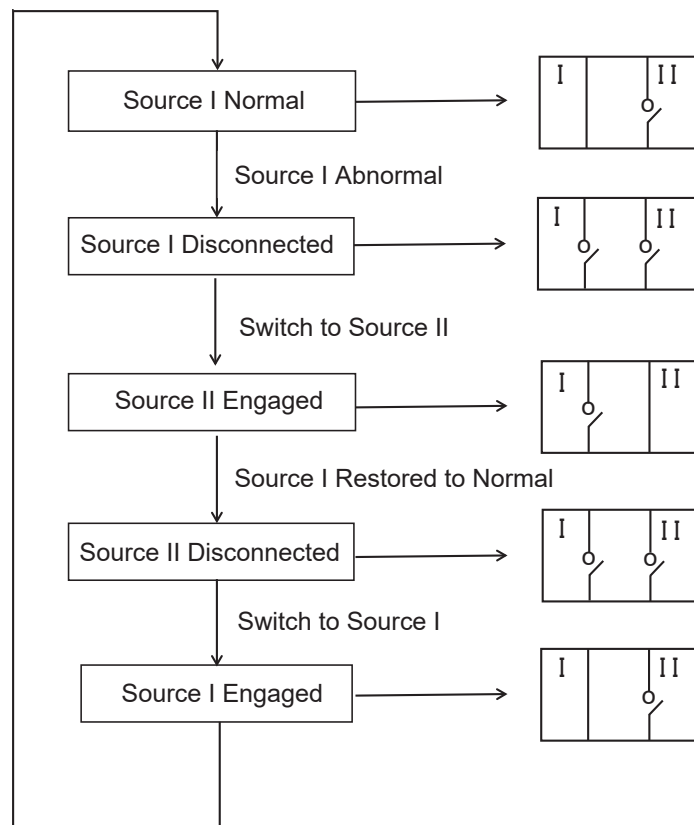

P type Power-Power

■ G & D type ATSE transfer logic

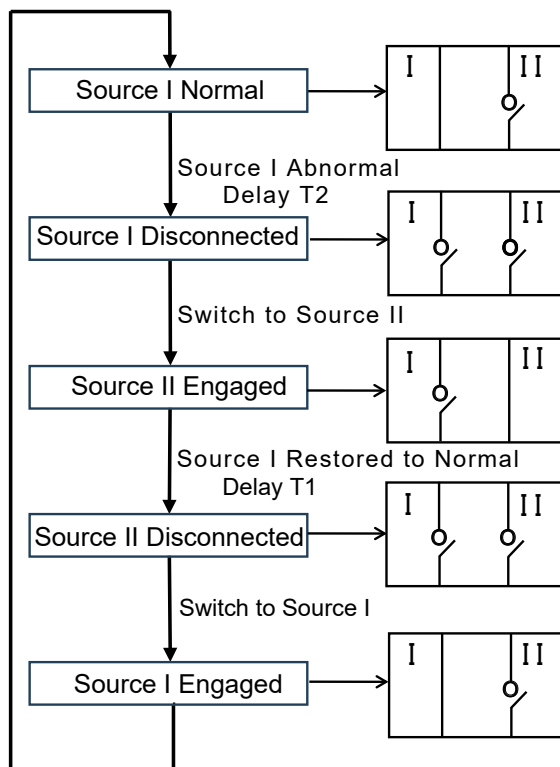

T1: Source I recovery to Source I switch-on time.
 T2: Source II recovery to Source II switch-on time.
 T3: Time to start generator upon Source I failure.
 T4: Time to stop generator after Source I restoration.

Notes:
 Source I: Primary Power Source
 Source II: Alternative Source
 T1: Adjustable range: 0–90s.
 T2: Adjustable range: 0–90s.
 T3: Adjustable range: 0–240s.
 T4: Adjustable range: 0–240s.

Power-Power

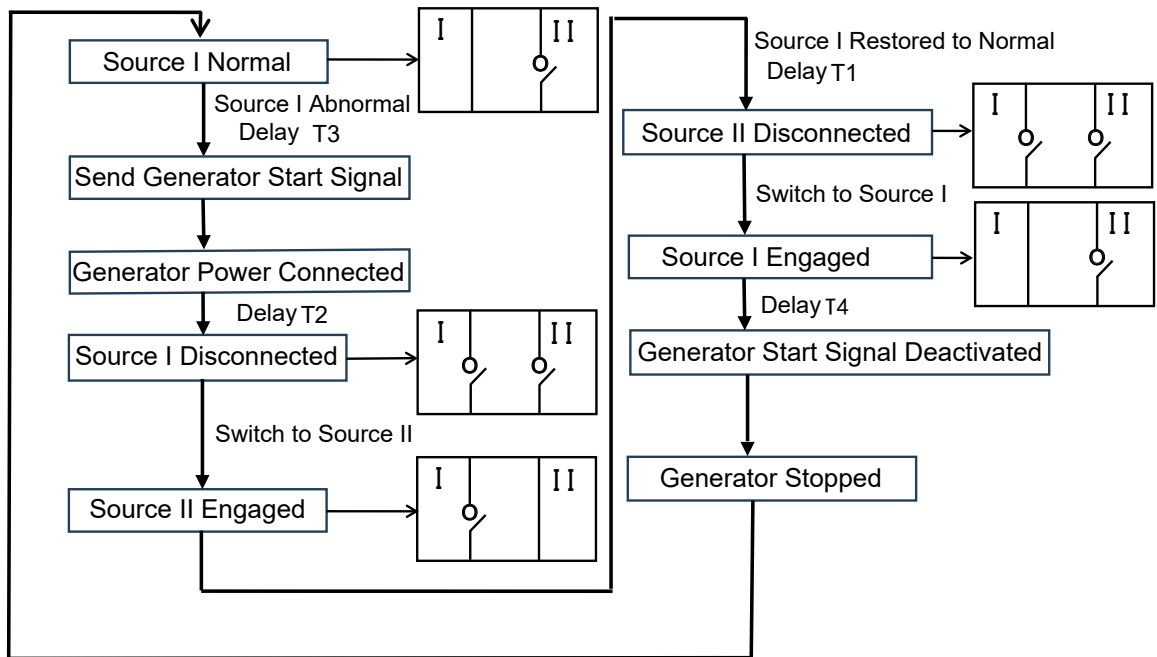

Power-Generator

Dimensions and connections



■ Dimensions and connections

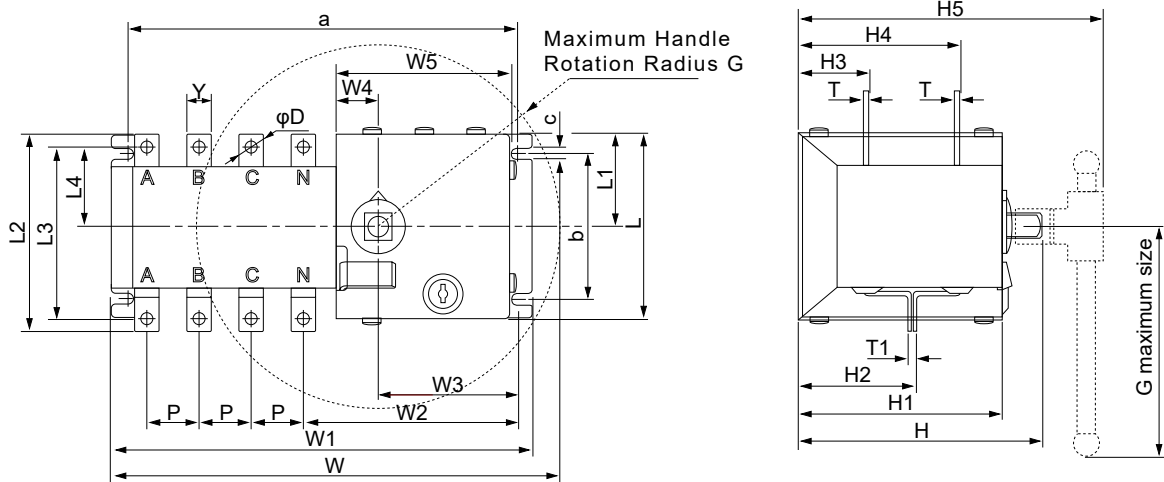

Dimensions Frame Size		External dimensions			Installation dimensions			Busbar dimensions									
		W1	L2	H	a	b	c	A1	B1	C1	C2	D1	D2	R	φ	h	
100AF	2P/3P	233	118	141	215	83	6.5	6.5	/	/	/	8	10.2	/	6	2.55	
	4P	243	116		230			7	/	/	/	8	10.2	/	6	2.55	
160AF	2P/3P	265	142	195	245	102	7	10	/	/	/	10	15	/	8.5	3.5	
	4P	305	147		284			10	/	/	/	10	15	/	8.5	3.5	
250AF	2P/3P	312	176	210	292	106	7	12.5	/	/	/	13.5	15.5	/	10.5	3.5	
	4P	370	164	195	347	102		12.5	/	/	/	13.5	15.5	/	10.5	3.5	
800AF	800 3P	375	287	267	350	180	9	22.5	/	/	/	22	31	/	12.5	6	
	800 4P	435			412			22.5	/	/	/	22	31	/	12.5	6	
1600AF	3P	630-1000A	520	325	350	220	11	12	36	15	30	6	20	6	/	8	
		1250A			370			496	22	36	18	30	6	22	6	/	8
		1600A			370			496	22	36	18	30	6	22	6	/	10
	4P	630-1000A	635	325	350	220	11	12	36	15	30	6	20	6	/	8	
		1250A			370			606	22	36	18	30	6	22	6	/	8
		1600A			370			606	22	36	18	30	6	22	6	/	10
3200AF	3P	2000A	420	505	495	219	11	20	40	18	35	/	57	/	13	10	
		2500A	430					20	40	18	35	/	62	/	13	10	
		3200A	440					20	40	18	35	/	65	/	13	18	
	4P	2000A	420	610	495	219	11	20	40	18	35	/	57	/	13	10	
		2500A	430					20	40	18	35	/	62	/	13	10	
		3200A	440					20	40	18	35	/	65	/	13	18	



Dimensions and connections

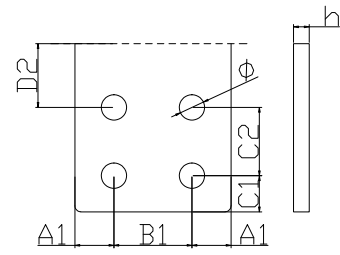
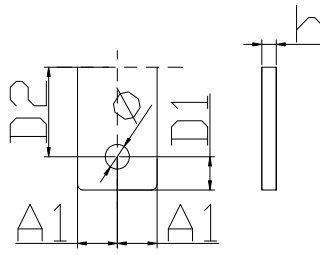
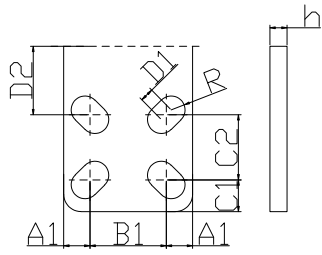

Other dimensions																				
	W	W2	W3	W4	W5	P	Y	ΦD	L	L1	L3	L4	H1	H2	H3	H4	H5	T	T1	G
	255	124	82	24.5	102	30	13	7	107	53.5	103	45	117	40	40	93	170	2.5	2.5	115
	270						14							68						
	320	160	91	30.5	110	37	20	8.5	140	76.5	122	53	164	59	57	130	230	3.5	3.5	144
	348			156.5						34				115						
	362	165	94	32	110	50	25	10	140	76.5	148	70	180.5	64	65	146	244.5	3.5	3.5	144
	412		91	35						115				77						
	525	186	88.5	45	124	65	45	12	220	115	243	116	237	81	83	193	297	6	6	250
	590	181																		
	780	190	84.5	44	123	120	60	-	250	125	-	-	293	255	108	250	385	8	8	540
							80								109			251	10	
	1080	188	84.5	44	123	120	60	-	250	125	-	-	293	255	108	250	385	8	8	540
							80								109			251	10	
	785	202	87	44	120	120	80	-	248	100	-	-	473	80/435	80/200	315/435	560	10	10	540
														85/440	85/205	320/440		15	15	
	1080	202	87	44	120	120	80	-	248	100	-	-	473	90/445	90/210	325/445	560	20	20	540
														80/435	80/200	315/435		10	10	
	1080	202	87	44	120	120	80	-	248	100	-	-	473	85/440	85/205	320/440	560	15	15	540
														90/445	90/210	325/445		20	20	

